

High Efficiency solid state amplifiers

EME Conference 2010, Dallas Texas
Goran Popovic AD6IW

- Performance reliability and life expectancy of RF semiconductor devices are inversely related to the device temperature. Reduction in the device temperature corresponds to an exponential increase in the reliability and life expectancy of the device
- Lower power consumption, longer battery life
- Lower heat dissipation, smaller amplifier size, weight and heat sink size
- Lower Power supply and heat sink requirements
- Better Amplifier Linearity
- Lower Cost
- Possibilities to mount amplifier and PSU close to antenna and eliminate cable loss

- Maximum efficiency of a RF power device is a function of frequency, temperature, input drive level, load impedance, bias point, device geometry, and intrinsic device characteristics.
- How well a device converts one energy source to another.
- Heat as byproduct
- Efficiency depends on amplifier class, gain, output power and power dissipation.
- Highest efficiency at peak output power PEP, P1db

Overview:

Drain efficiency

$$\eta_D = \frac{P_{RFout}}{P_{dc}} = \frac{P_{RFout}}{V_{ds} \cdot I_d}$$

Power added efficiency, PAE

$$\delta_{power-added} = P.A.E. = \frac{P_{RFout} - P_{RFIn}}{P_{DC}} = \frac{P_{RFout} - P_{RFIn}}{V_{DC} \times I_{DC}}$$

Drain Efficiency and PAE

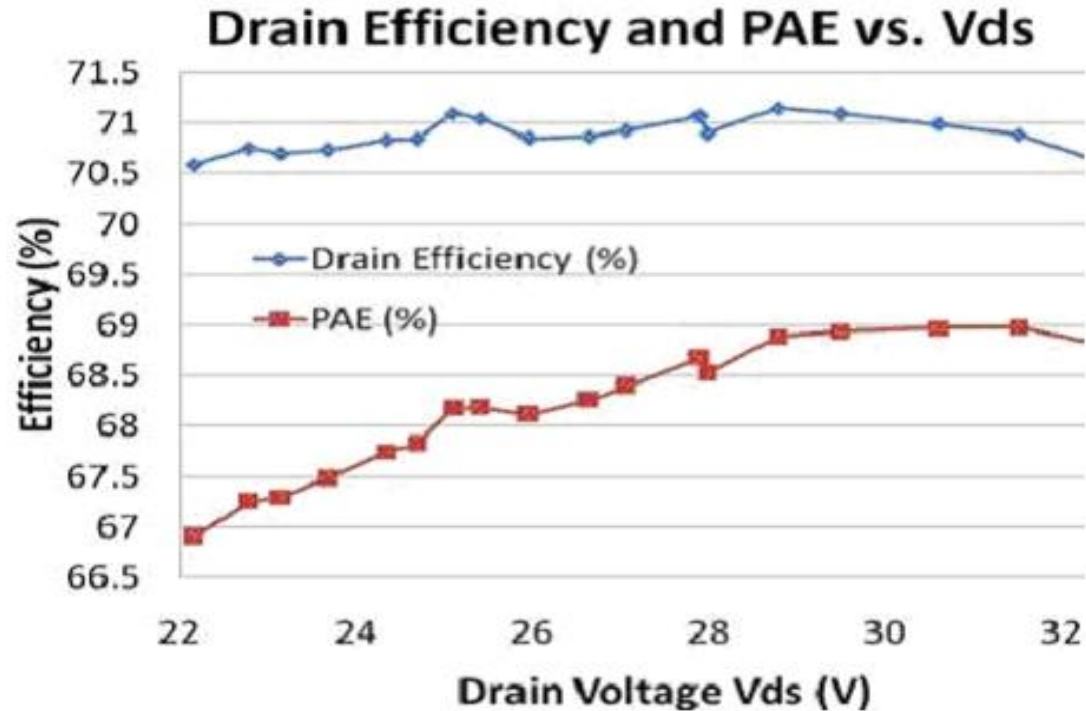

Drain Efficiency and PAE as a function of Vds for a class B LDMOS power amplifier

Average efficiency $\eta_{AVG} = P_{outAVG}/P_{inAVG}$

Drain Efficiency and PAE vs. Vds

- Si BJT, high collector breakdown voltage, typically operate at 28V, up to 5 GHz and up to 1kW pulse applications. Positive temp coefficient, temperature runaway
- Vertical RF power MOSFET, 1KW at HF, hundreds of Watts at VHF.
Typically operate at 12V, 28V or 50V, and some at >100V
- LDMOS UHF and lower uW frequencies, typically operate at 28V, 50V
hundred watts @ 2GHz, low cost. L band Si LD MOS > 50 % efficiency
- GaAs MESFET, higher mobility – higher frequencies, 200W @ 2GHz, 40W @ 20GHz,
Low breakdown voltage, typically operate from 5V to 10V.
Depletion mode, require negative bias voltage, poor linearity
- X band MESFET amps with 10 % BW up to 30 %
- GaAs HEMT high ft up to 150 GHz, 15W at 12GHz PAE 50%
100W at S band

RF Transistors Technologies

- PHEMT High efficiency up to 45GHz, and useful to 80GHz, 40W at L band
- X Band PHEMT amps can exceed 40% PAE, Ka Band 20 % to max. 30 %
- SiC MESFET high mobility and break-down voltage, double than Si LDMOS, Power densities ten times that of a GaAs MESFET, high thermal conductivity. Typically operate at 48V, and power levels 10 to 60W up to 2GHz.
- The cost of Sic is ten times that of Si LDMOS

RF Transistors Technologies

- GaN HEMT same as SiC even higher mobility and higher operational frequencies, High breakdown voltage, low thermal resistance, 8W at 10GHz with 30% efficiency. Soft compression, not for class A, but ideal for AB, E, F class. High cost.
- HBT, SiGe experimental power amplifier HBT 200W at L band
- Wideband amps, low efficiency 2-18GHz 10 %
- TWT 60 %

RF Transistors Technologies

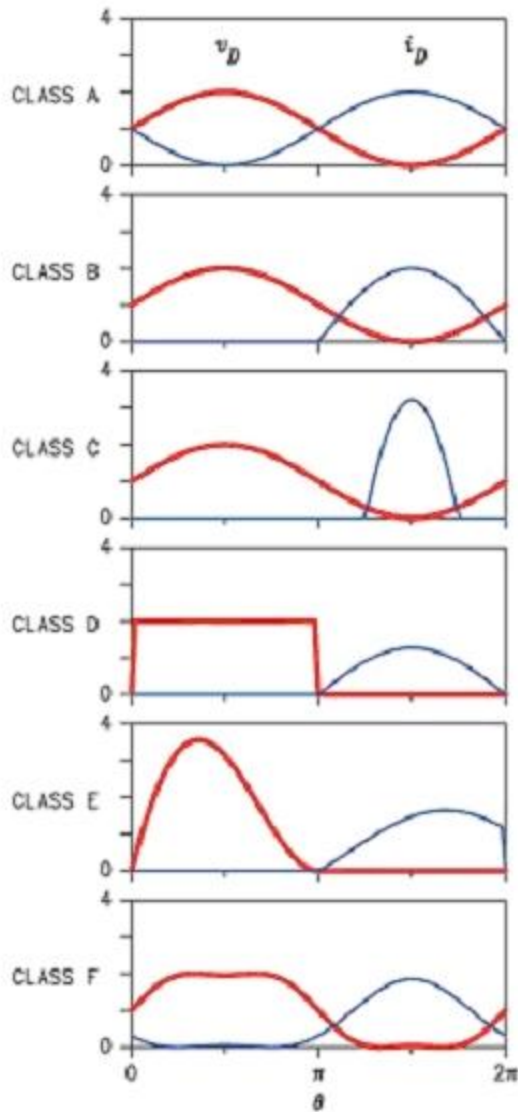

Class A amplifier, high quiescent current, 360 deg Conducting angle, highest gain, frequency and Linearity. Low efficiency, theoretical 50 %

Class B amplifier, the quiescent drain current is Zero, but in praxis 10% of drain current. Ideal for push pull amps. Efficiency theoretical 78.5 %

Class C gate is biased below threshold, transistor is active less than half cycle 150 deg. Linearity is lost for higher efficiency 85 %

Class D generate square wave drain voltage waveform. Theoretical Eff 100%, suffer from Drain capacitance, saturation. Up to 1KW at LF/ HF

Class E operate as switch, no V/I overlapping KW HF amplifier with switching transistors. Drain capacitance and saturation. Eff 100%

Class F voltage waveform half square form and Current sine wave. Inverse F class. Max. efficiency depends upon the number of harmonics

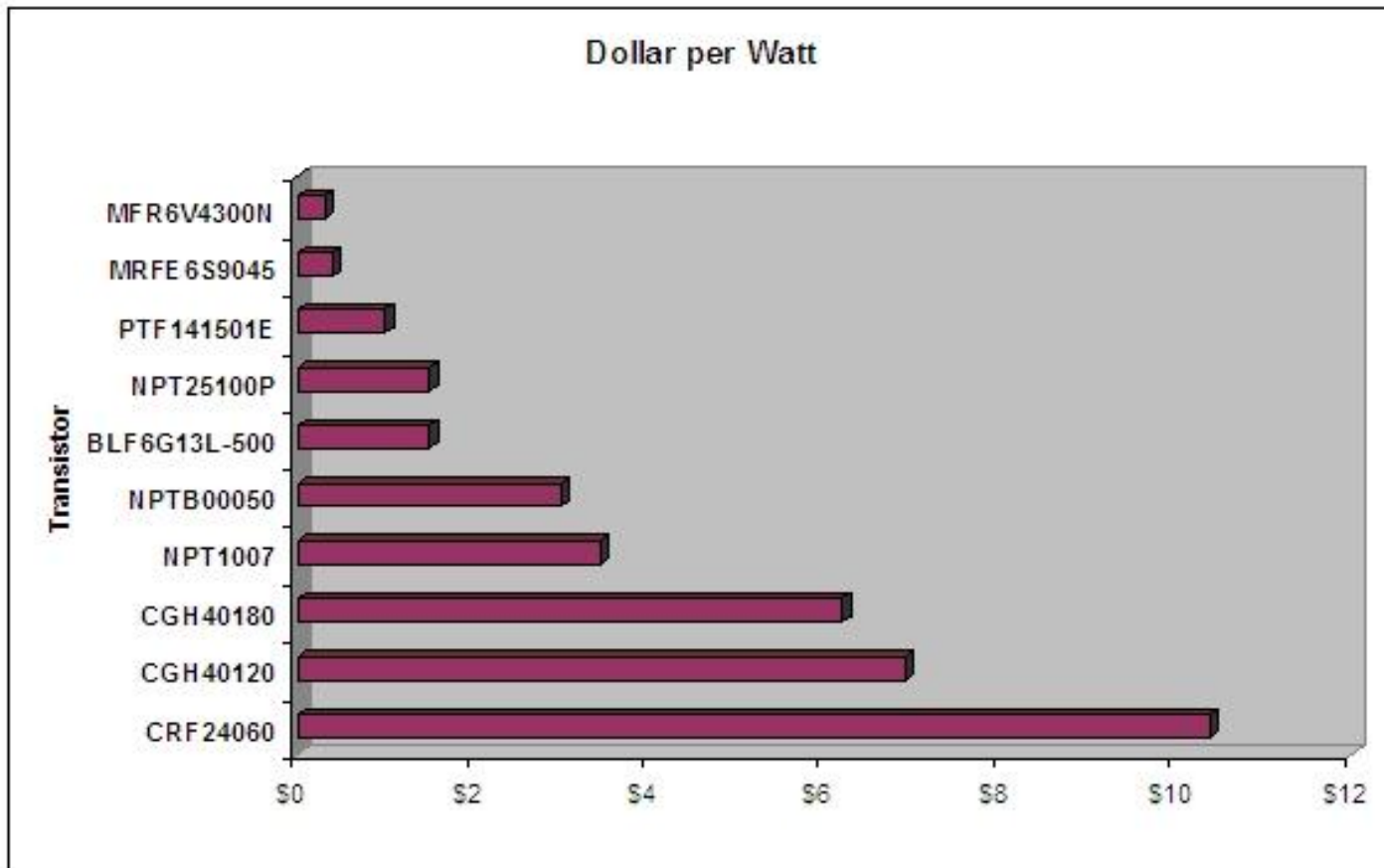

Dollar per Watt Chart for SiC, GaN and LDMOS Transistors

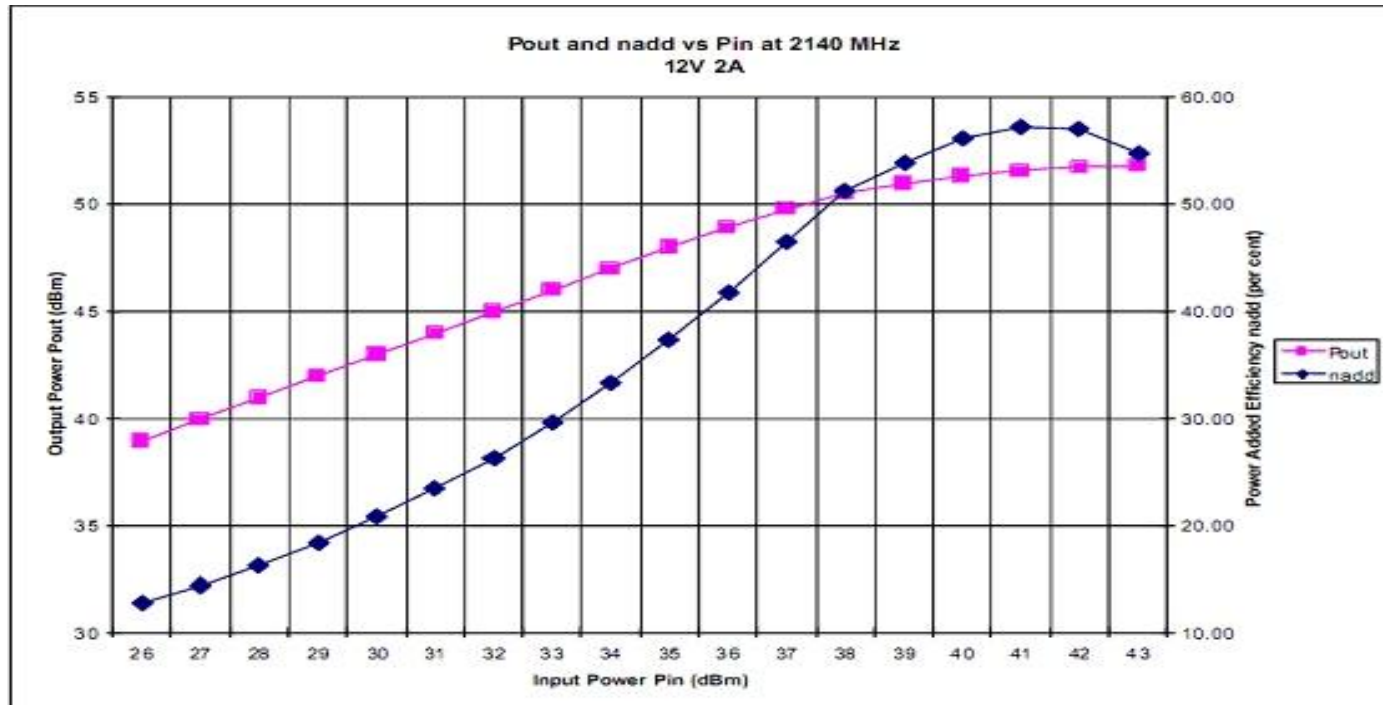
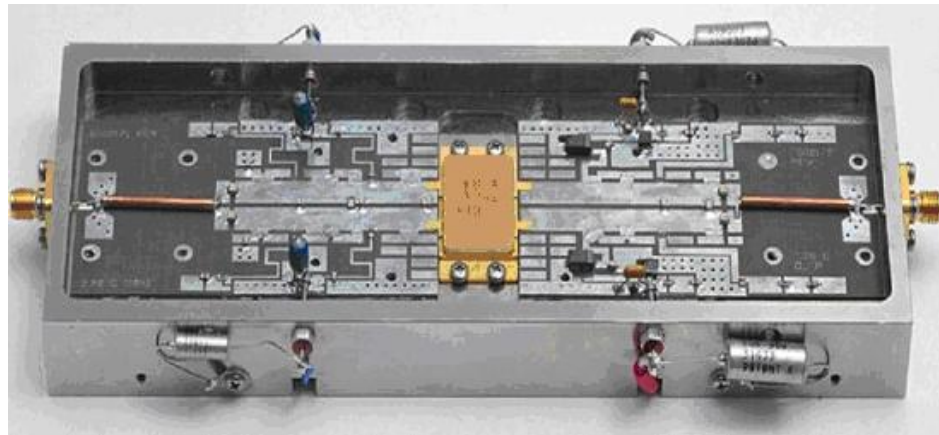

Fujitsu FLL1500UI 150W GaAs FET push pull power amplifier

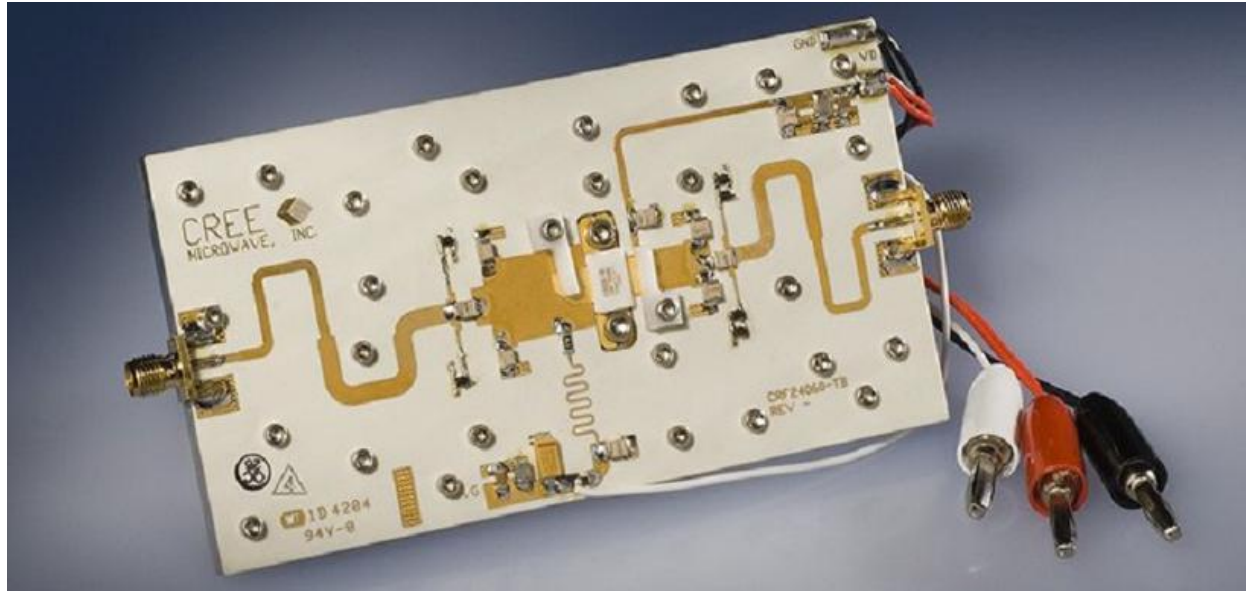

Cree Sic CRF24060, drain efficiency 45% @ 1500MHz,
60W transistor price \$ 623 (RELL)

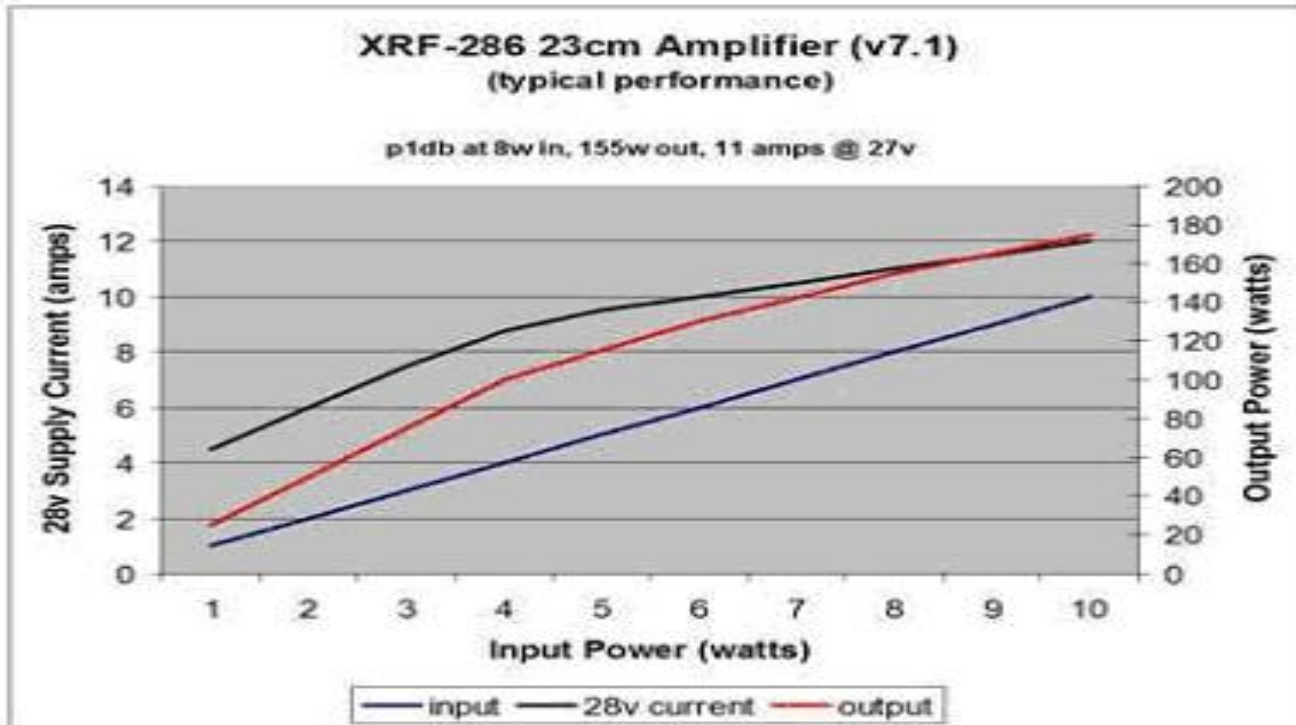

Amplifier with pair of obsolete XRF-286,
Gain 12dB

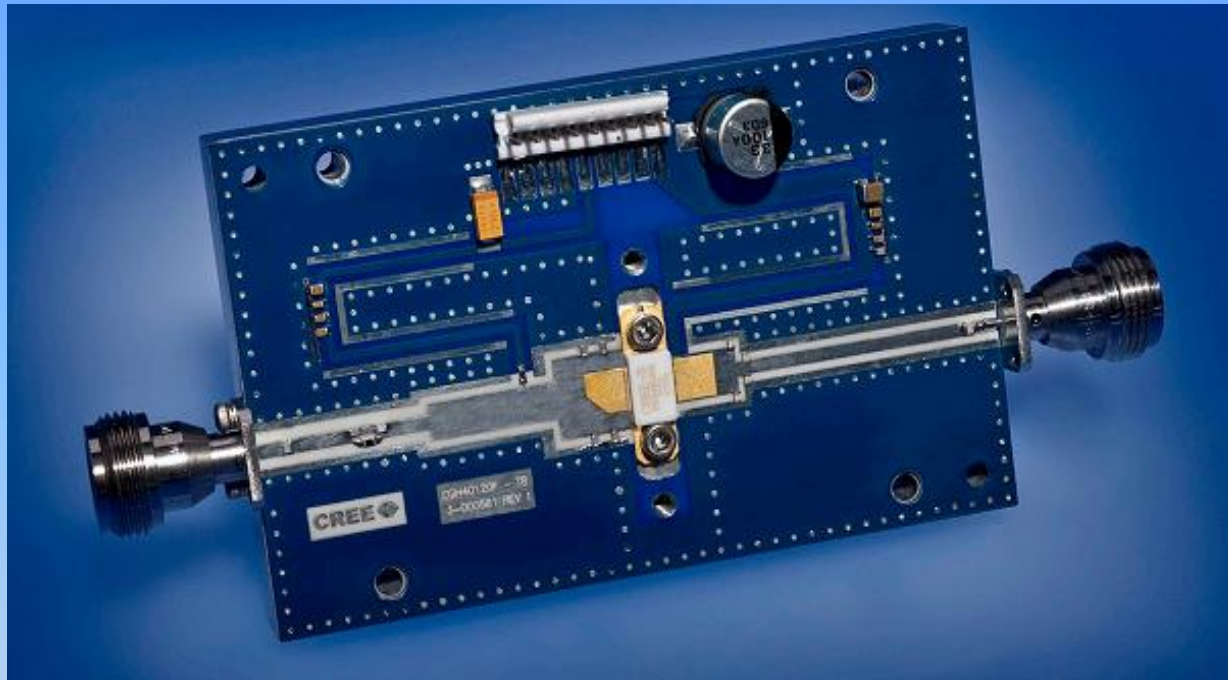

Cree GaN 120W efficiency 70% at P_{sat} , up to 4GHz, transistor price is \$ 831 (RELL)

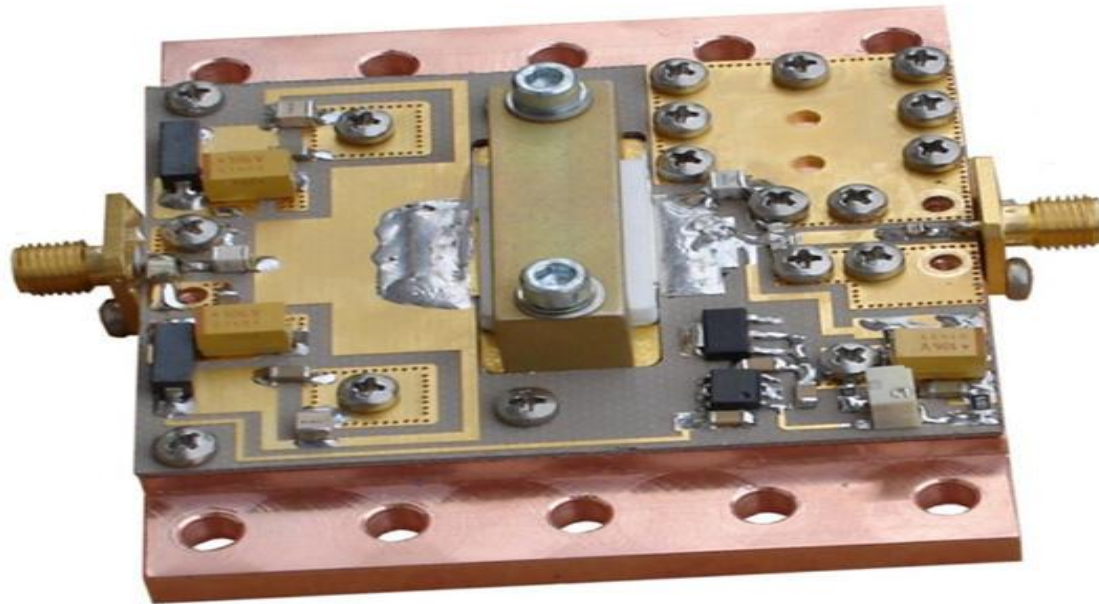

Infineon PTF141501E 150W Efficiency 48%,
Transistor price is \$154 (RELL)

Freescal Semiconductor
Technical Data

RF Power Field Effect Transistors

N-Channel Enhancement-Mode Lateral MOSFETs

Designed primarily for pulsed wideband applications with frequencies up to 500 MHz. Devices are unmatched and are suitable for use in industrial, medical and scientific applications.

- Typical Pulsed Performance at 450 MHz: $V_{DD} = 50$ Volts, $I_{DD} = 150$ mA, $P_{out} = 1000$ Watts Peak (200 W Avg.), Pulse Width = 100 μ sec, Duty Cycle = 20%
Power Gain — 20 dB
Drain Efficiency — 64%
- Capable of Handling 10:1 VSWR, @ 50 Vdc, 450 MHz, 1000 Watts Peak Power

Features

- CW Operation Capability with Adequate Liquid Cooling
- Qualified Up to a Maximum of 50 V_{DD} Operation
- Integrated ESD Protection
- Excellent Thermal Stability
- Designed for Push-Pull Operation
- Greater Negative Gate-Source Voltage Range for Improved Class C Operation
- RoHS Compliant
- In Tape and Reel. R6 Suffix = 150 Units per 56 mm, 13 inch Reel.

Document Number: MRF6VP41KH
Rev. 4, 3/2009



MRF6VP41KHR6
MRF6VP41KHSR6

10-500 MHz, 1000 W, 50 V
LATERAL N-CHANNEL
BROADBAND
RF POWER MOSFETs



CASE 375D-05, STYLE 1
NI-1230
MRF6VP41KHR6



CASE 375E-04, STYLE 1
NI-1230S
MRF6VP41KHSR6

PARTS ARE PUSH-PULL

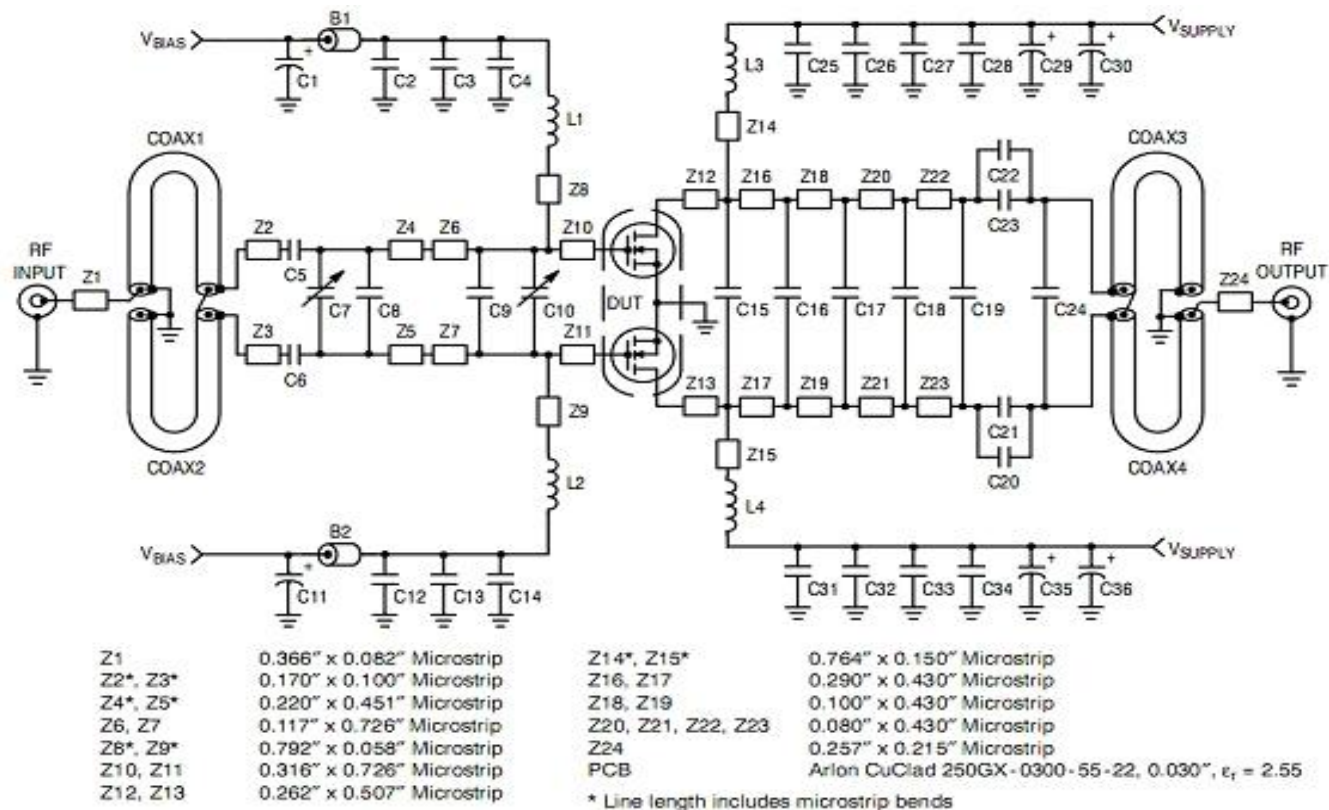
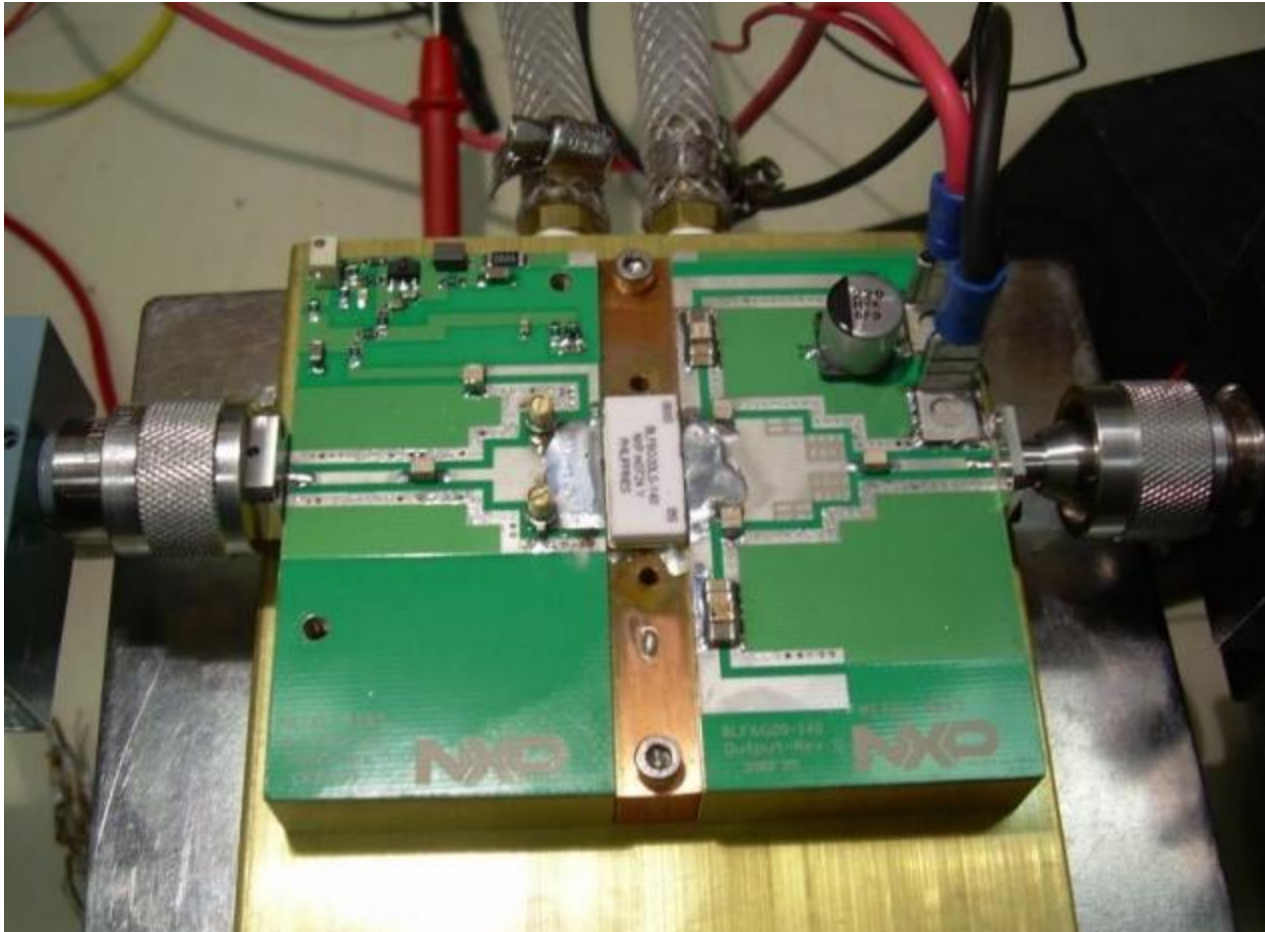
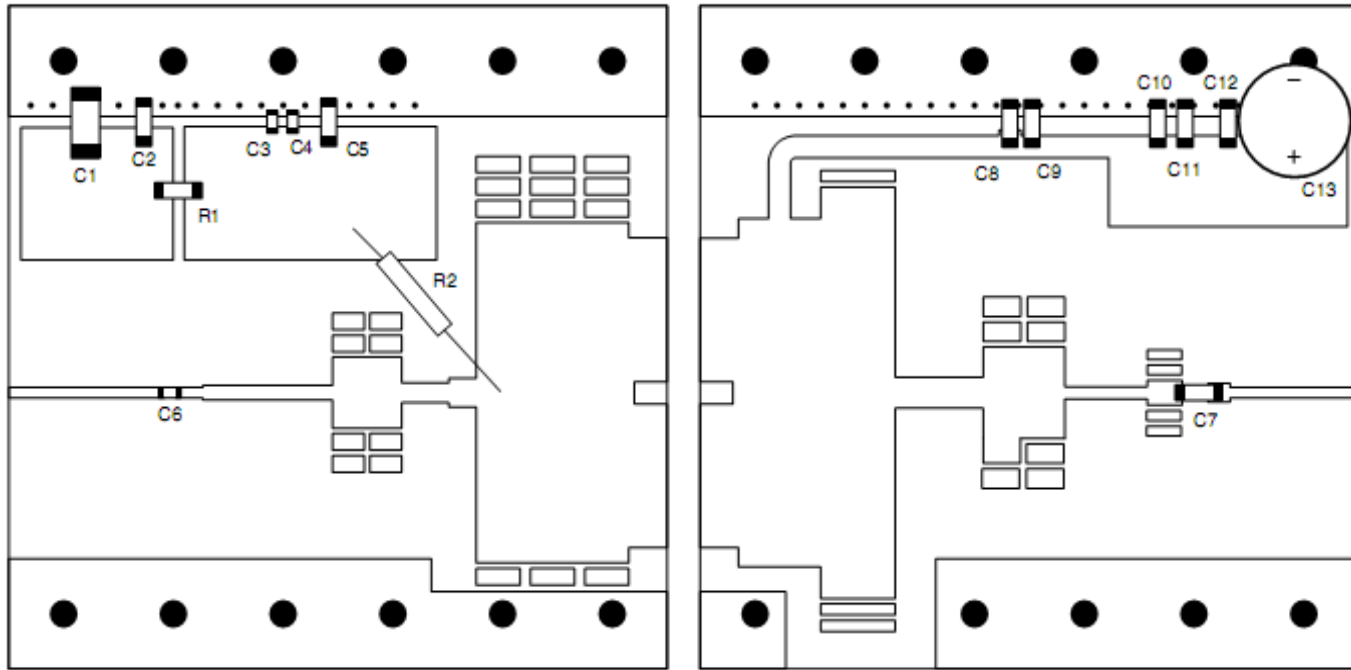

Figure 2. MRF6VP41KHR6(HSR6) Test Circuit Schematic — 450 MHz

CW Operation @ $T_c = 25$ deg. C 1107W
 Derate above 25 deg. C, 4.6 W/deg. C



NXP 2GHz LDMOS 200W amplifier, test setup



001aaj490

NXP BLL6H1214-500 1.2 to 1.4GHz amplifier 500W
pulse mode, Efficiency 50%,
Transistor price is \$ 529 (NXP)

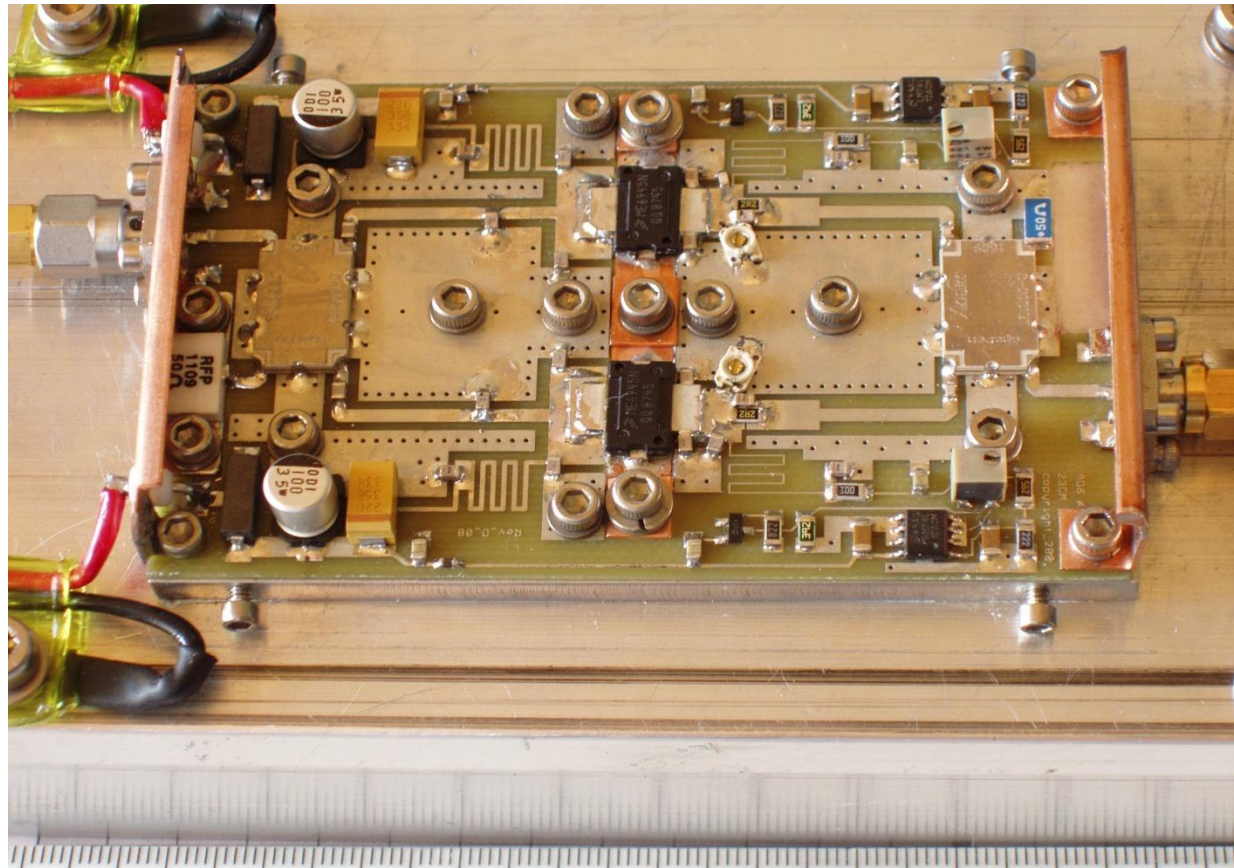

Freescale LDMOS 2 x MRF6S9045NR1 23cm
Amplifier, 17dB gain, Efficiency 53 % at Psat 125W.
Price for two transistors are \$ 50 (RELL). Transistors
are soldered on the cooper flanges.

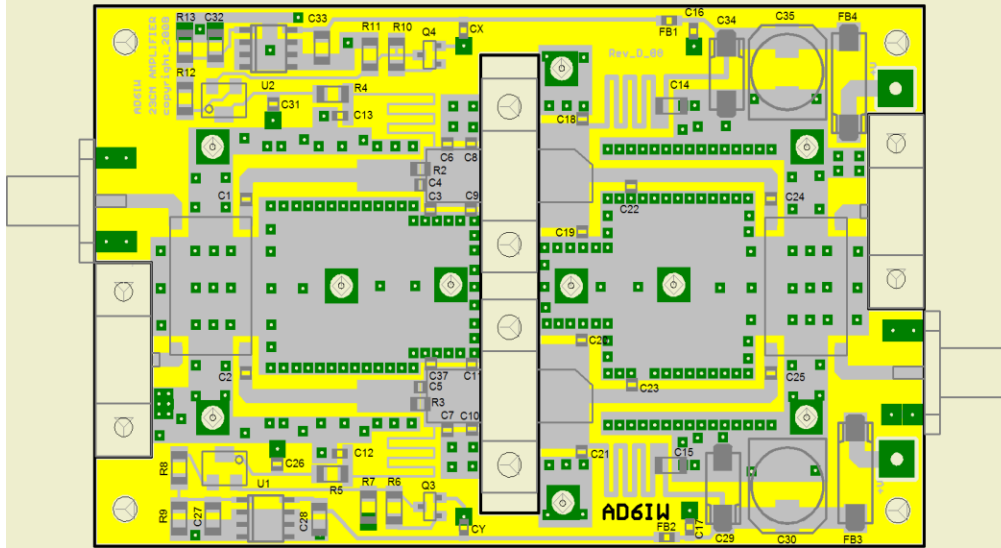

PCB 23cm amplifier layout

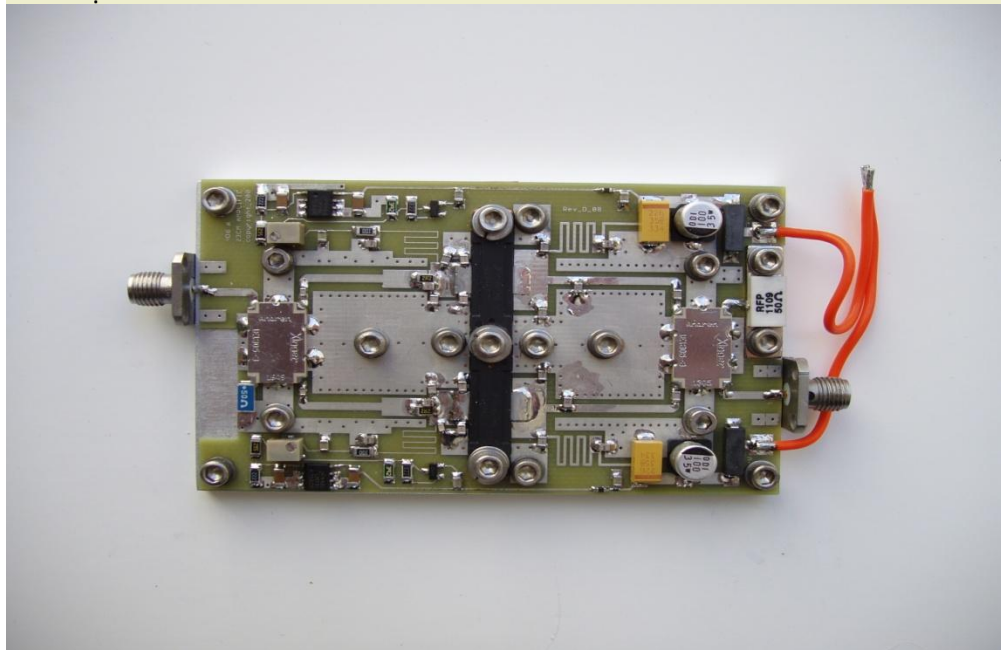

Amplifier mount on the heat spreader, pallet size 90 x 56 X 16 mm

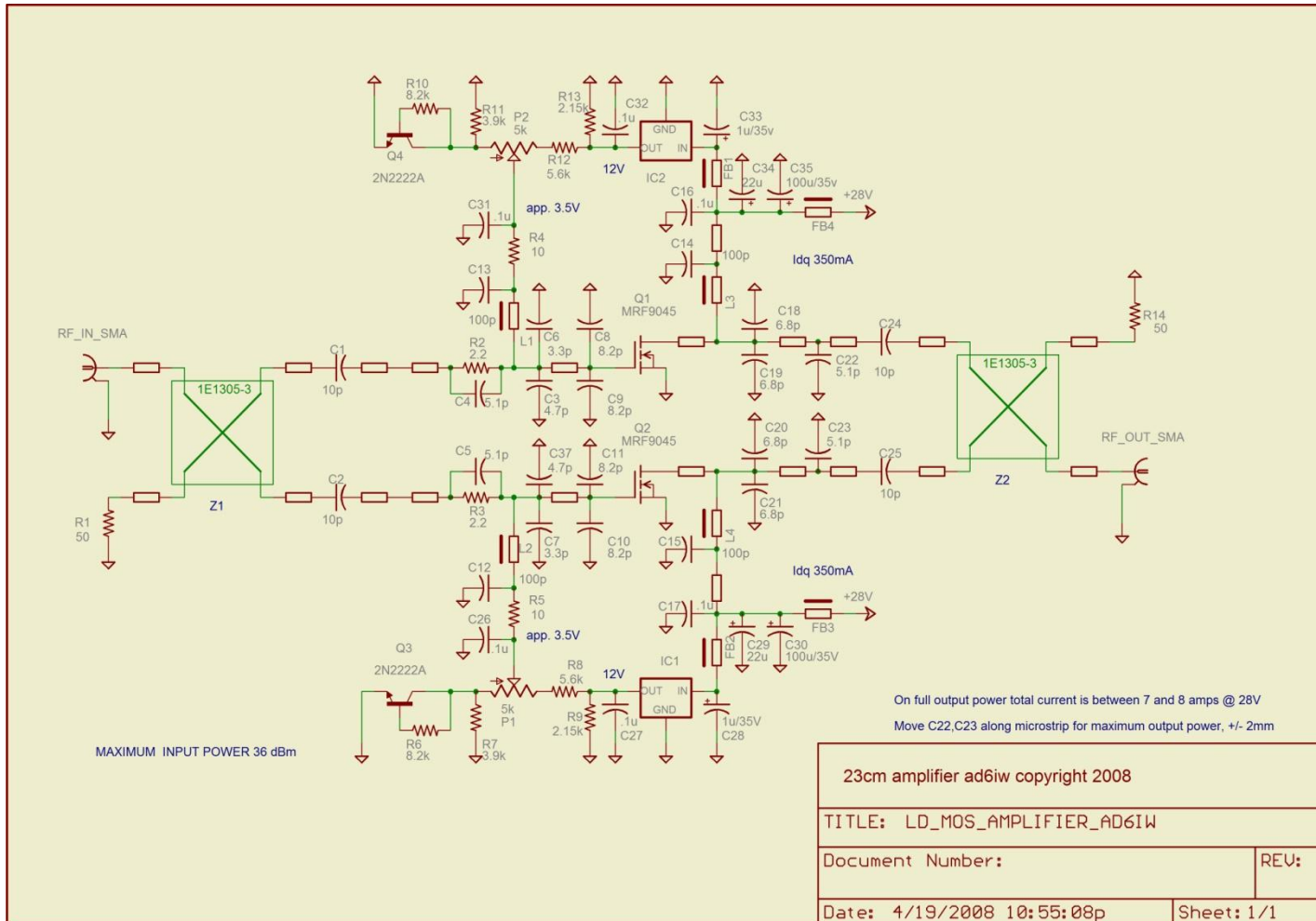

23CM amplifier schematics

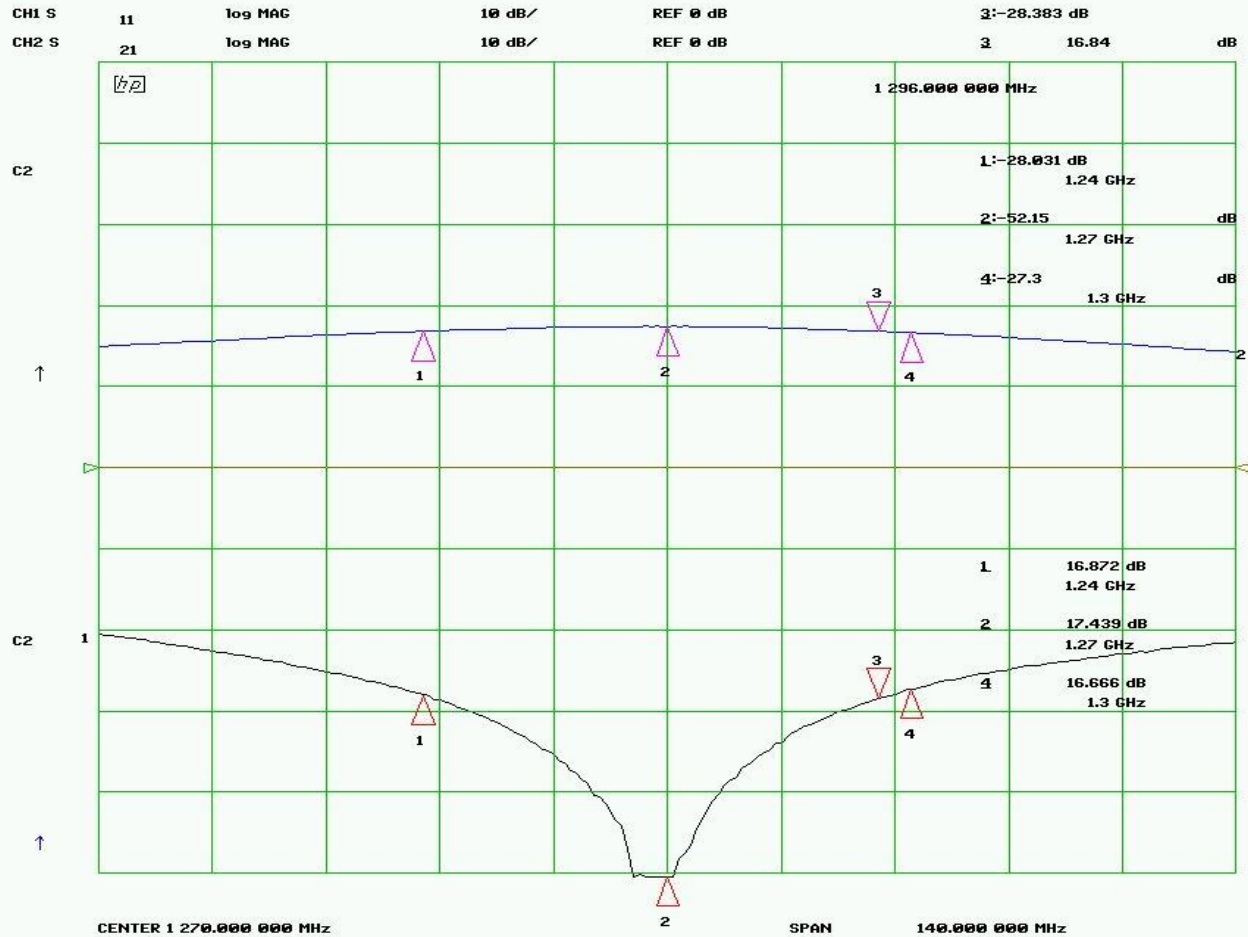

Gain and return loss. 1W drive in, > 40W out.
 Full power at 6-7 W drive.

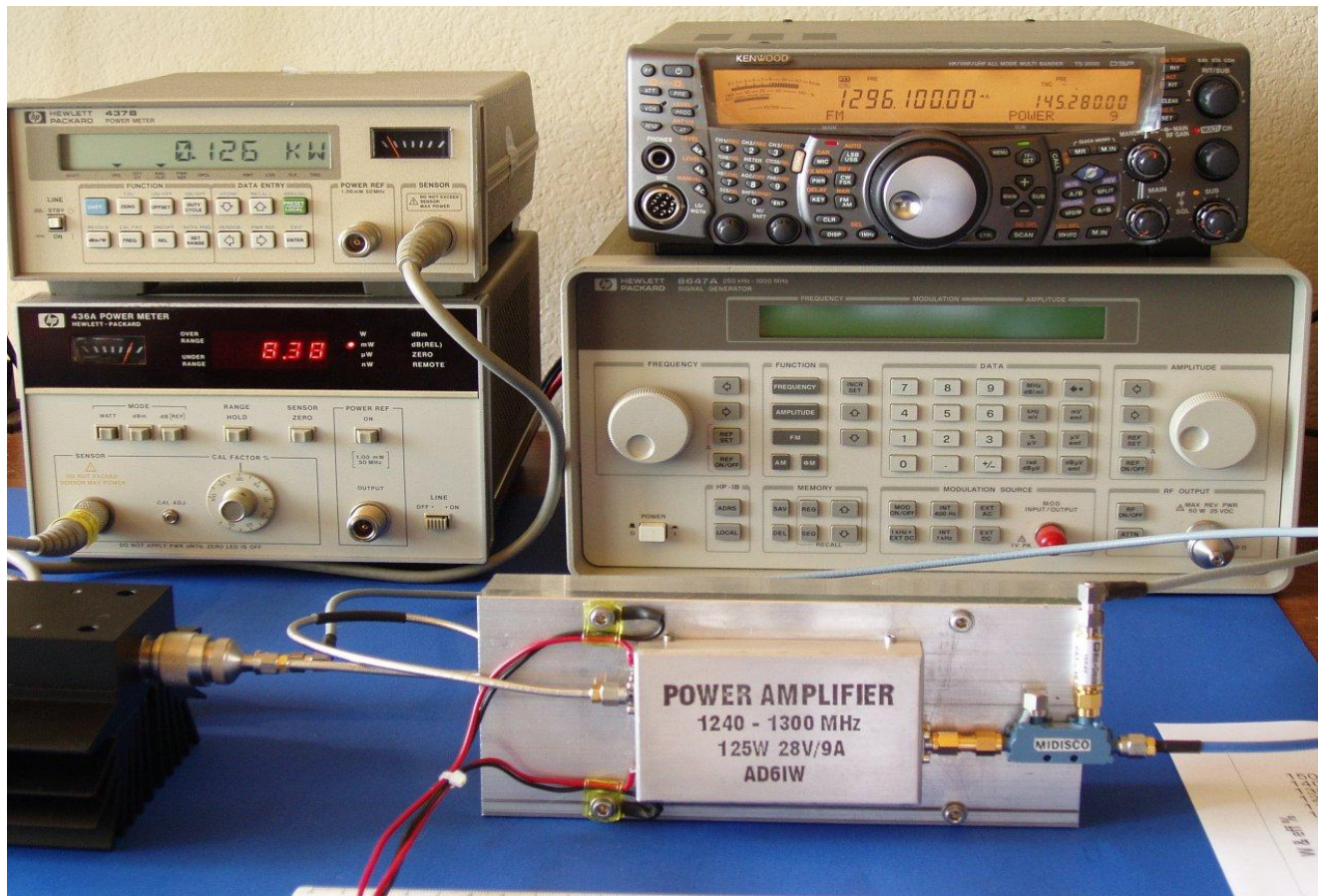

Amplifier prototype, compression test

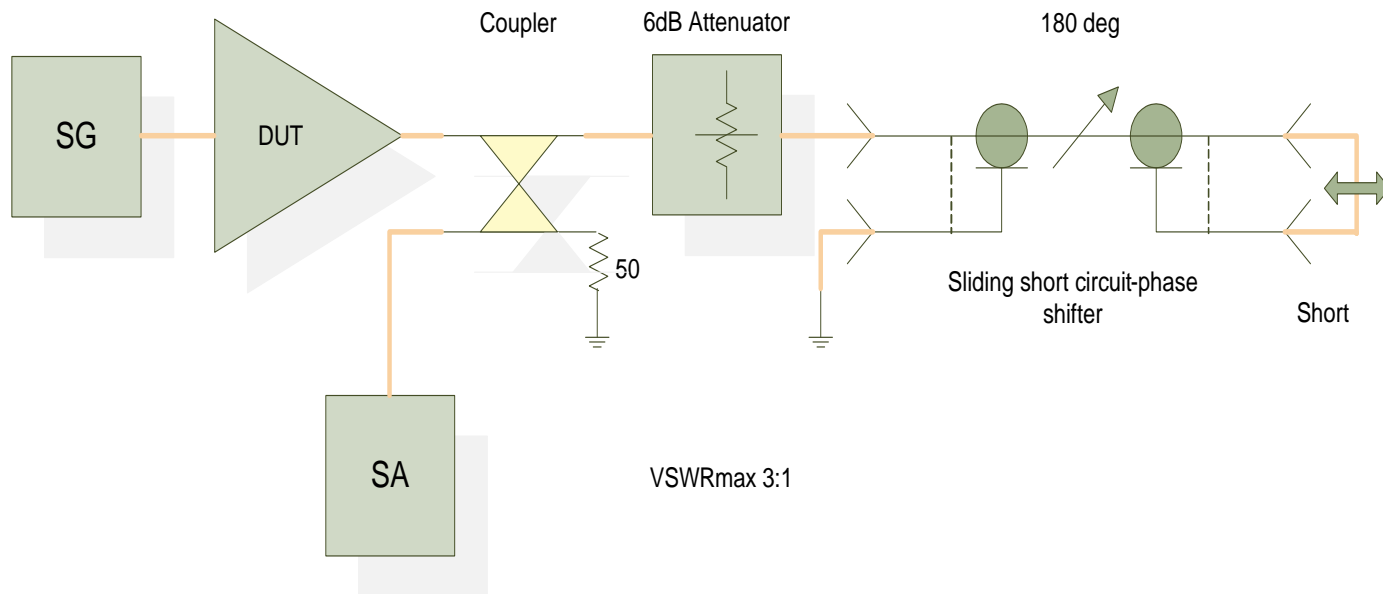

VSWR Test circuit block diagram

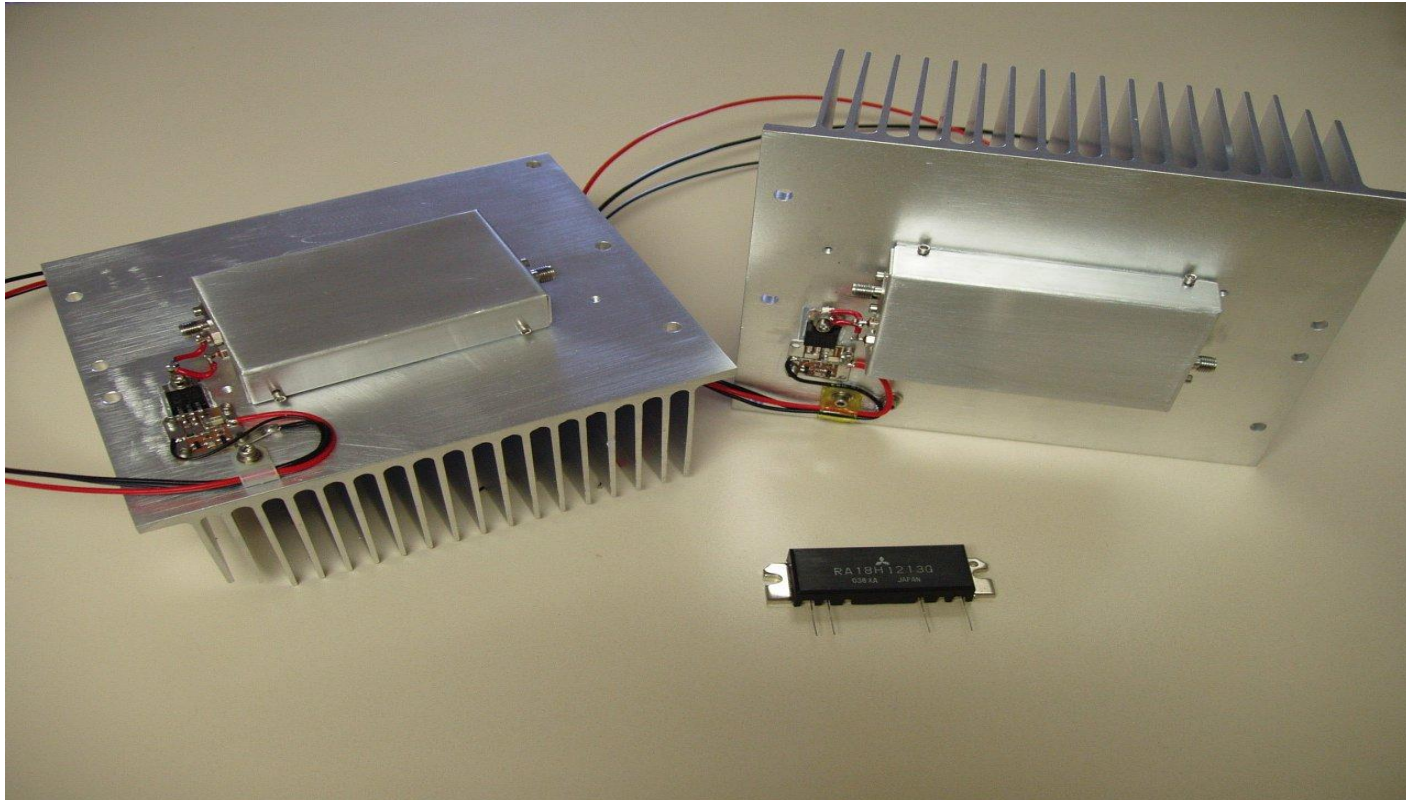

Ready made 125W 23cm amplifiers, scaled to Mitsubishi RA18H1213G 18W power module.
Efficiency of Mitsubishi RF MOSFET module is 28 % at P_{sat} , and 20 % at 18W output power.

- Thermal Management,
- LDMOS Bias temperature compensation, improves linearity
- Heat sink
- The primary purpose of a heat sink is to maintain the device temperature below the maximum allowable temperature specified by the device manufacture.
- Heat sink requirements, forced convection

Thermal resistance

$$Z_{TH_J-CASE} = \frac{(T_{J_MAX} - T_{CASE})}{P_{DISS}}$$

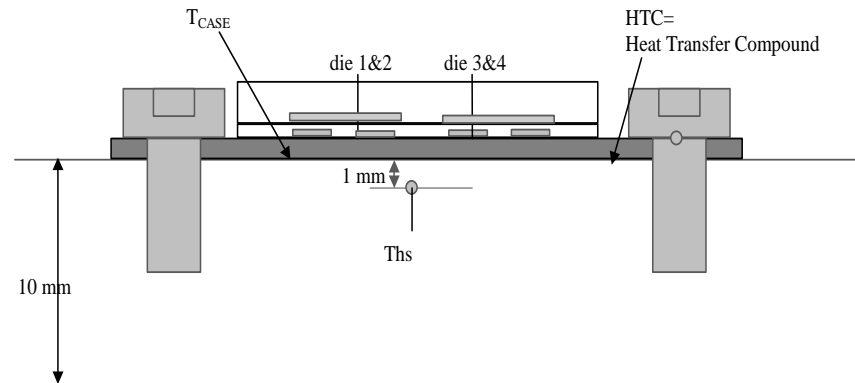
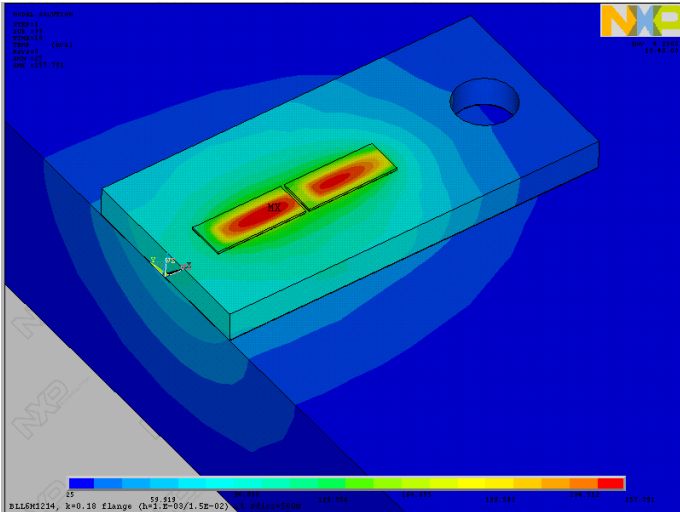

Steady state temperature distribution of the BLF6213S1 in SOT539 and definition of references (one half symmetry).

The device consists of four BLF6213S1 high voltage 6 dies.

Courtesy of NXP

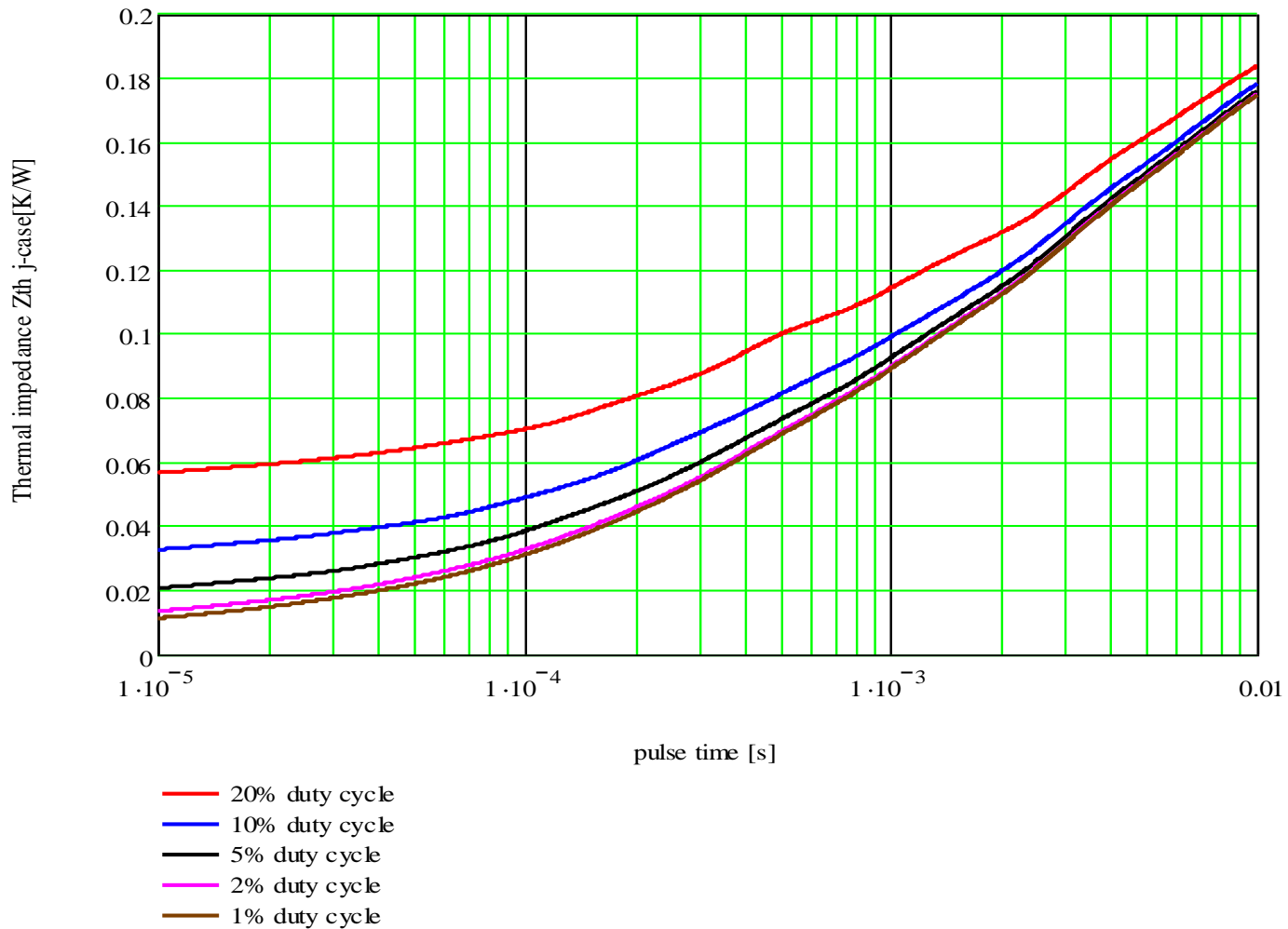

Simulated Thermal impedance at various pulse conditions Courtesy of NXP

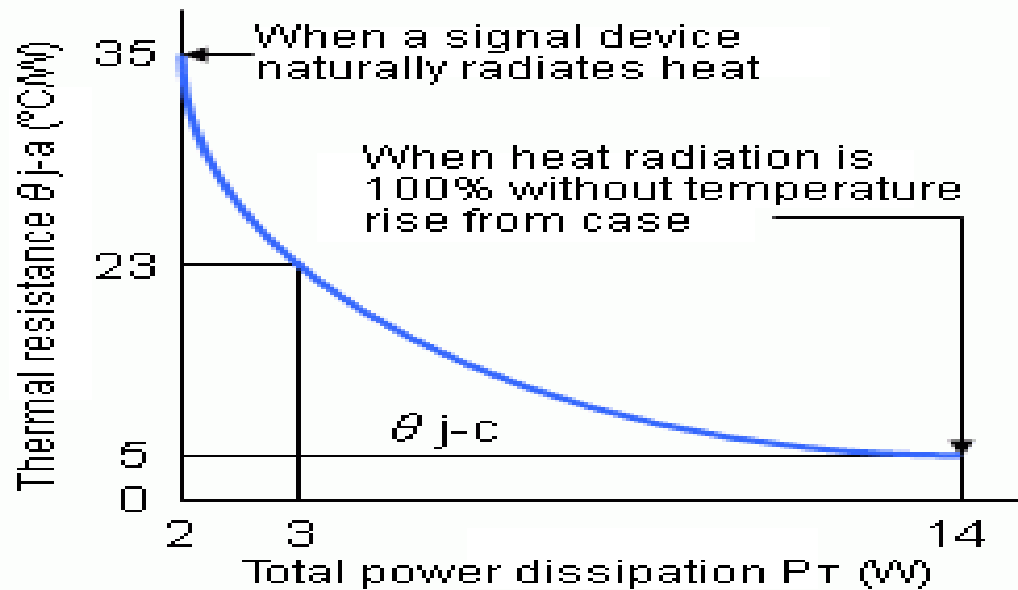

Power dissipation vs. Thermal resistance

Thermal conductivity is temperature depended. The higher the temperature, the lower will be its value.

Thermal conductivity (Kth) of ceramics and Semiconductors

Kth(W/m DegC)	
Alumina	37
AiN	230
BeO	250
GaAs	46
GaN	130
Si	145
SiC	350
Diamond	689
Copper	393

Heath Sink Requirements

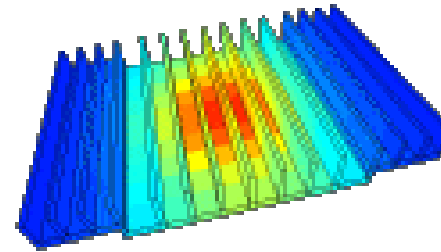

Low thermal resistance

Extruded, anodized or painted heat sink for forced convection cooling
Heath sink, width to length, heath dissipation capability 2:1.4

RF Transistor flanges

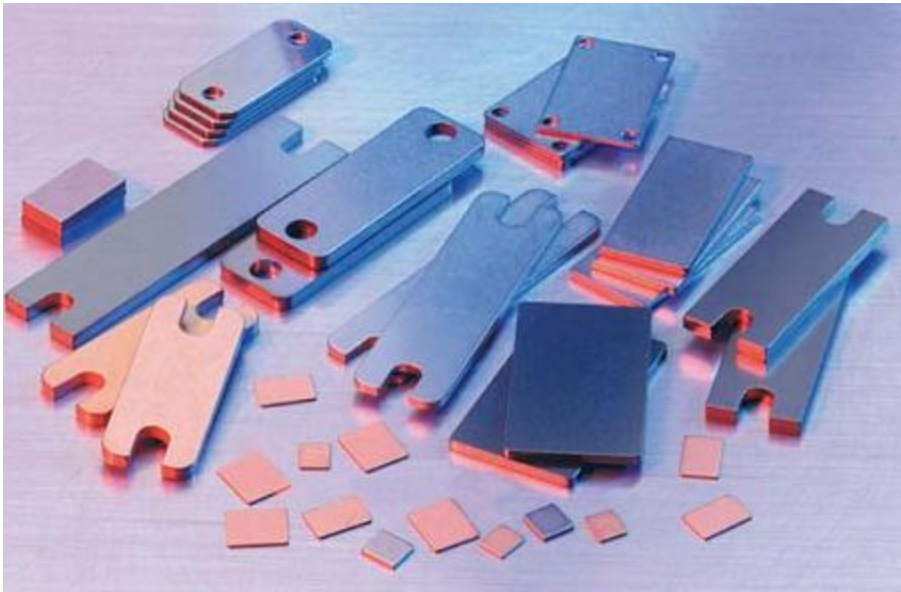

Requirements:

Thermal and electric conductivity,
expansion factor

Materials :

Copper, Tungsten/Copper-W/Cu,
Molybdenum/Copper-Mo/Cu,
Mo/Cu/Mo

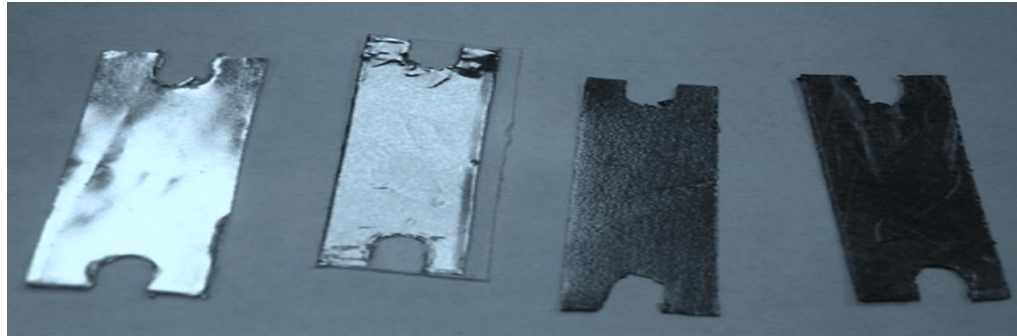

Interface Pads,
Indium foil,
Copper foil,
PGS and TGON pad

PGS is a crystalline graphite sheet 4mil (100 micron) thick, and
TGON is an amorphous graphite material 5 mil (125 micron) thick

Interface Material	V _{DD} V	I _D A	P _D W	Thermal Resistance °C/W	Voltage Drop through Interface mV
Thermal Grease	26.0	3.05	79.37	0.43	1.72
TGON-805	26.0	2.97	77.23	0.26	17.97
PGS	26.0	3.02	78.47	0.20	10.56
Indium Foil	26.0	3.03	78.88	0.25	2.05
Copper Foil	26.0	3.07	79.72	0.26	1.98

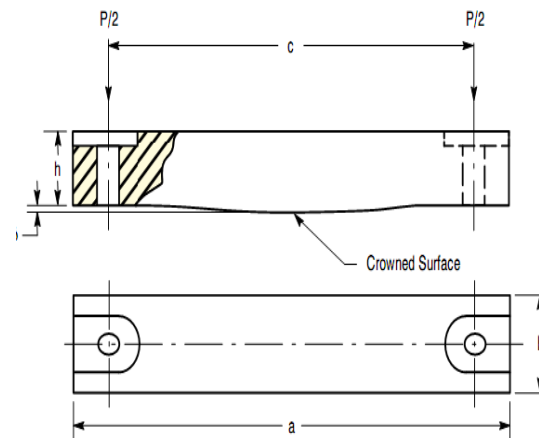
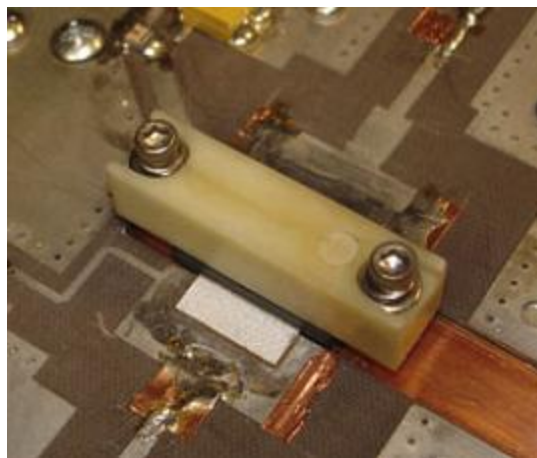

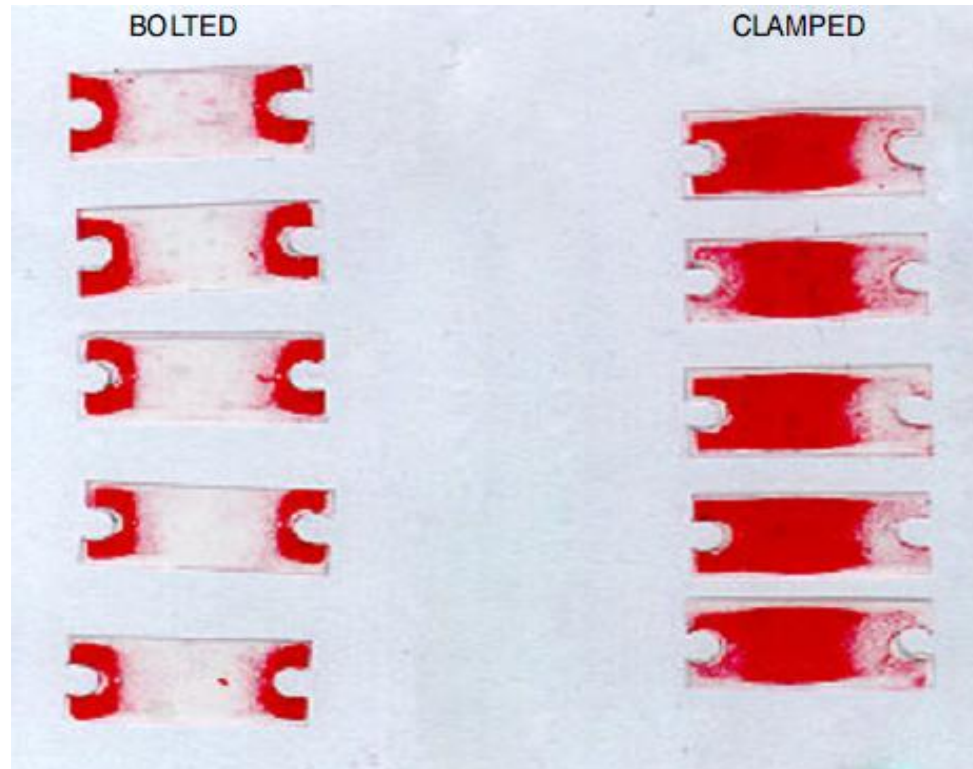

Pressure test bolted vs. clamped

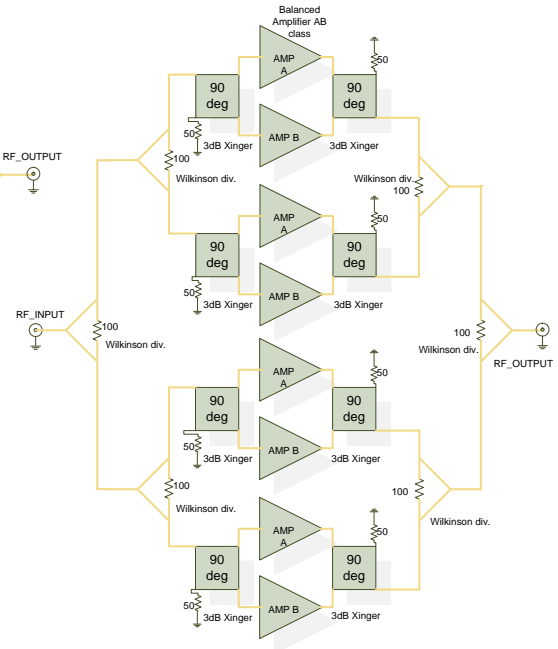
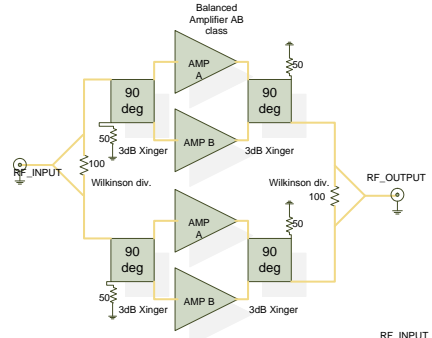
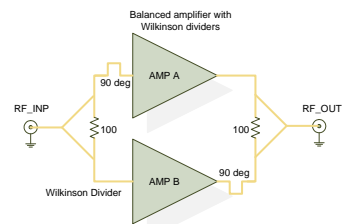
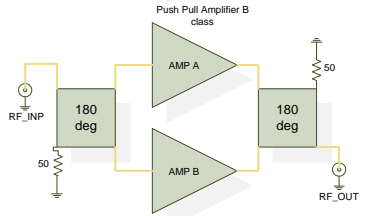
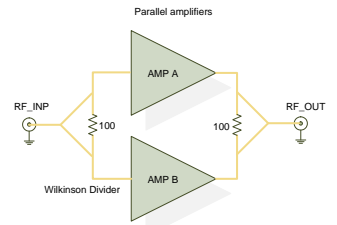
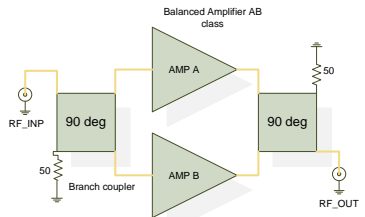

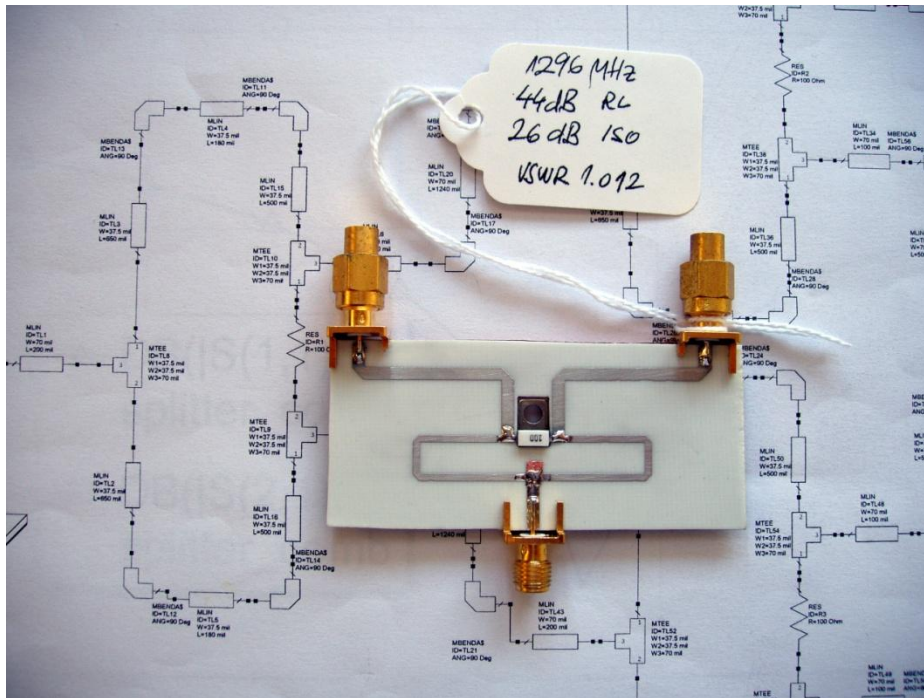

Wilkinson Divider prototype

VSWR

$$R_{diss} = 25W$$

$$P_{out} = 500W$$

$$\rho = \sqrt{R_{diss} / P_{out}}$$

$$VSWR = \rho + 1 / \rho - 1$$

$$VSWR_{max} = 1.6$$

Power resistor dissipation

$$\text{Max } VSWR \text{ } 3:1$$

$$\rho = (VSWR - 1) / (VSWR + 1)$$

$$\rho = 0.5$$

$$R_{diss} = \rho^2 \times P_{out}$$

$$R_{diss} = 125W$$

$$RL = -20 \log \rho$$

$$RL = 6.02 \text{ dB}$$

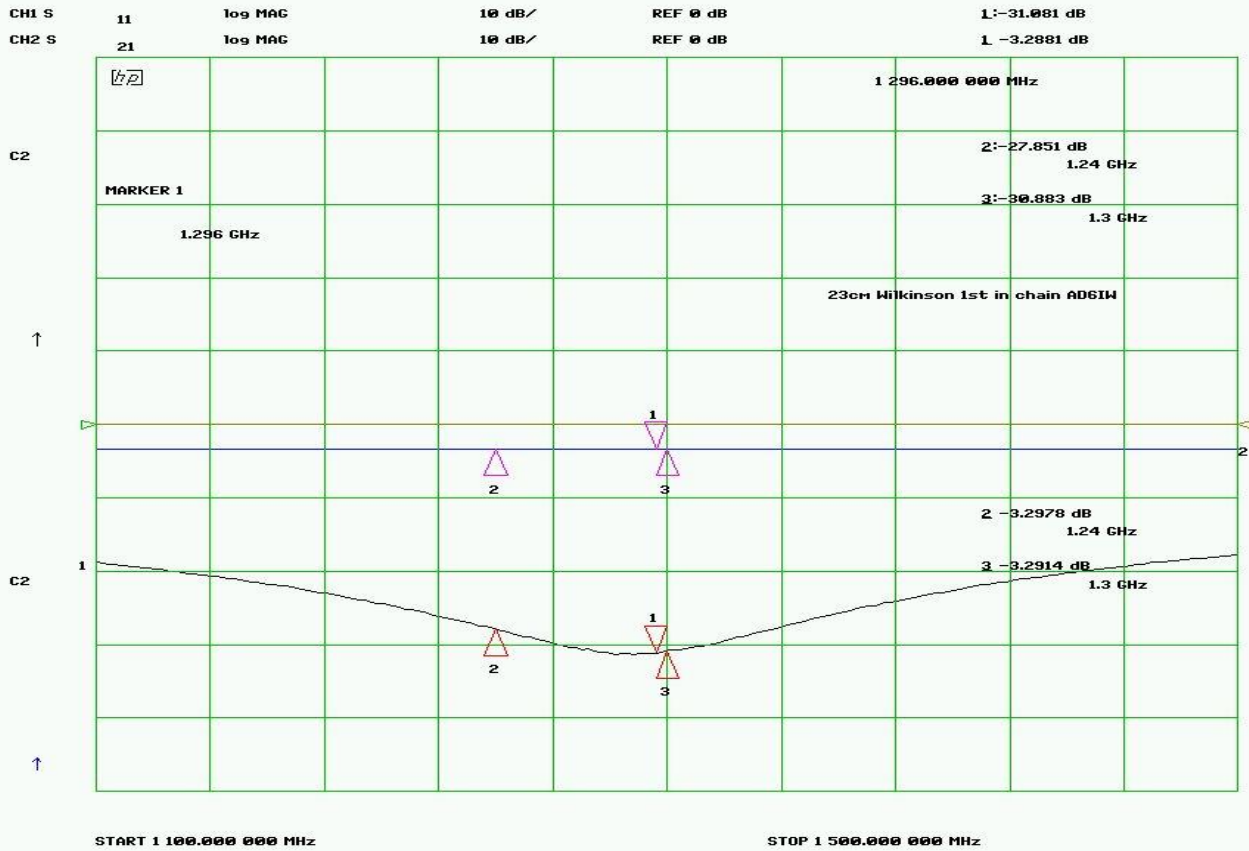

Wilkinson Divider for 23cm, S11 and S22

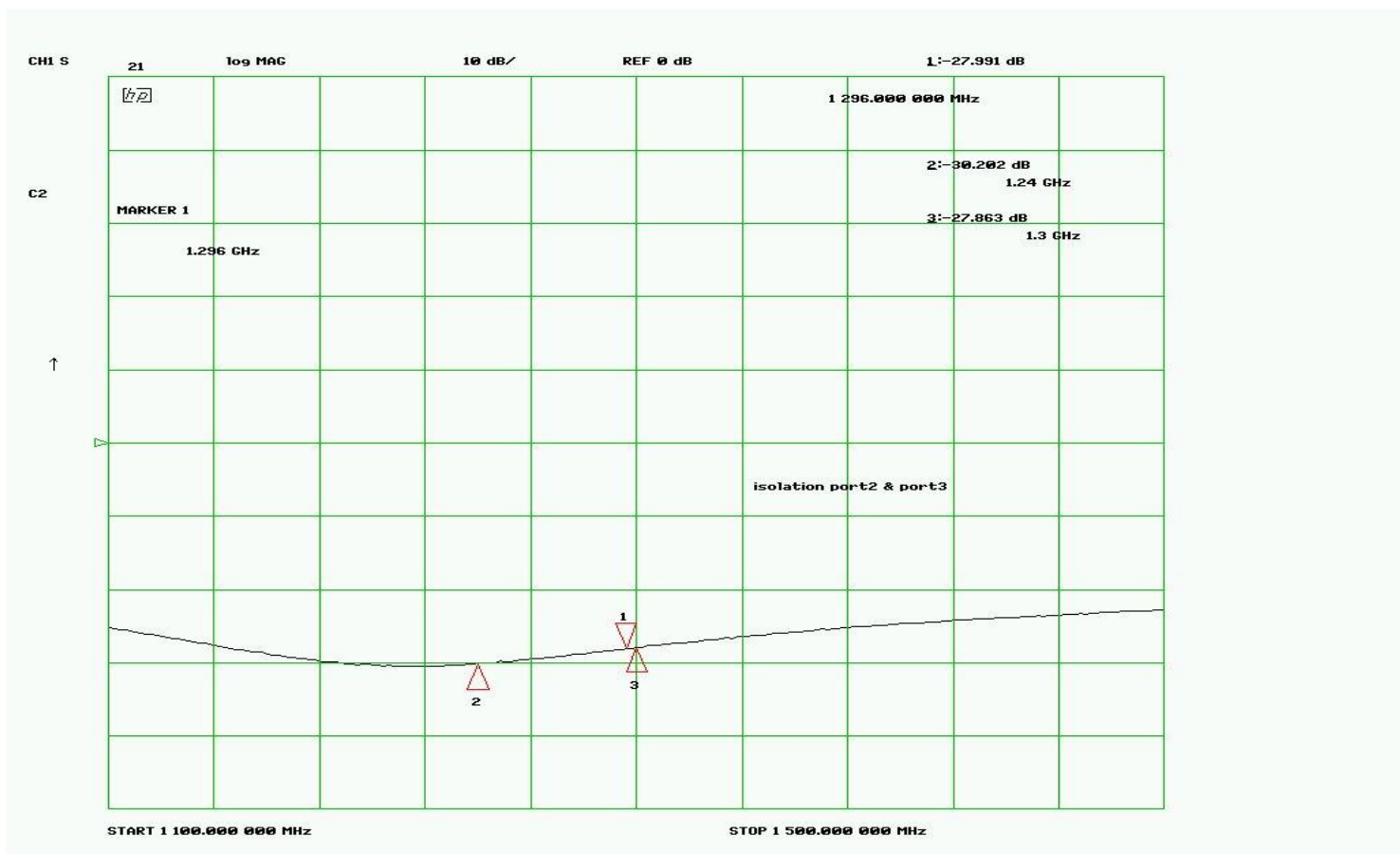

Wilkinson Divider for 23cm, Isolation S23

Wilkinson Divider for 23cm, Isolation S23

$P2 - P3 > 25\text{dB}$
 $P4 - P5 > 25\text{dB}$
 $P2, P3 - P4, P5 > 50\text{dB}$
 $P1$ to $P2, P3, P4, P5$
phase difference ± 0.5 degree
Insertion loss < 1 dB
IRL > -25 dB

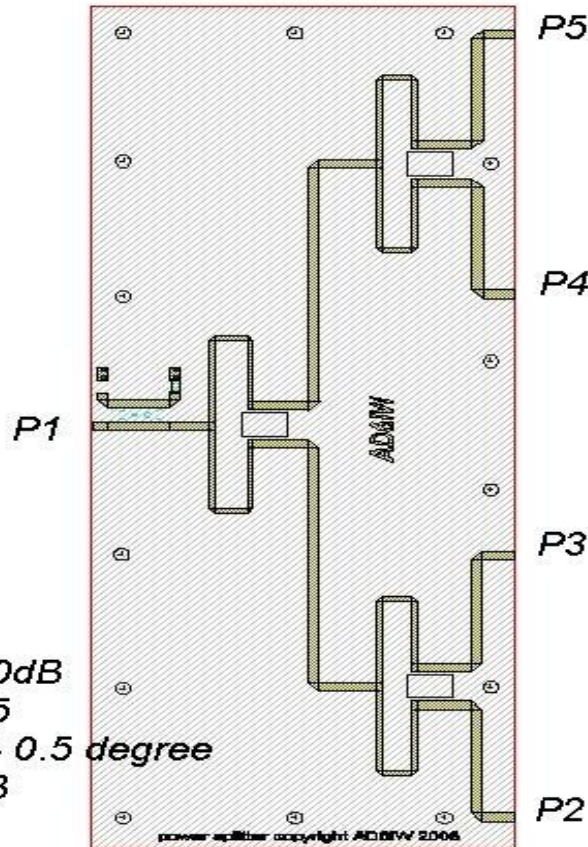

Four port Wilkinson Divider for 23 cm on Rogers 31 mils (0.78mm) R4003 substrate.

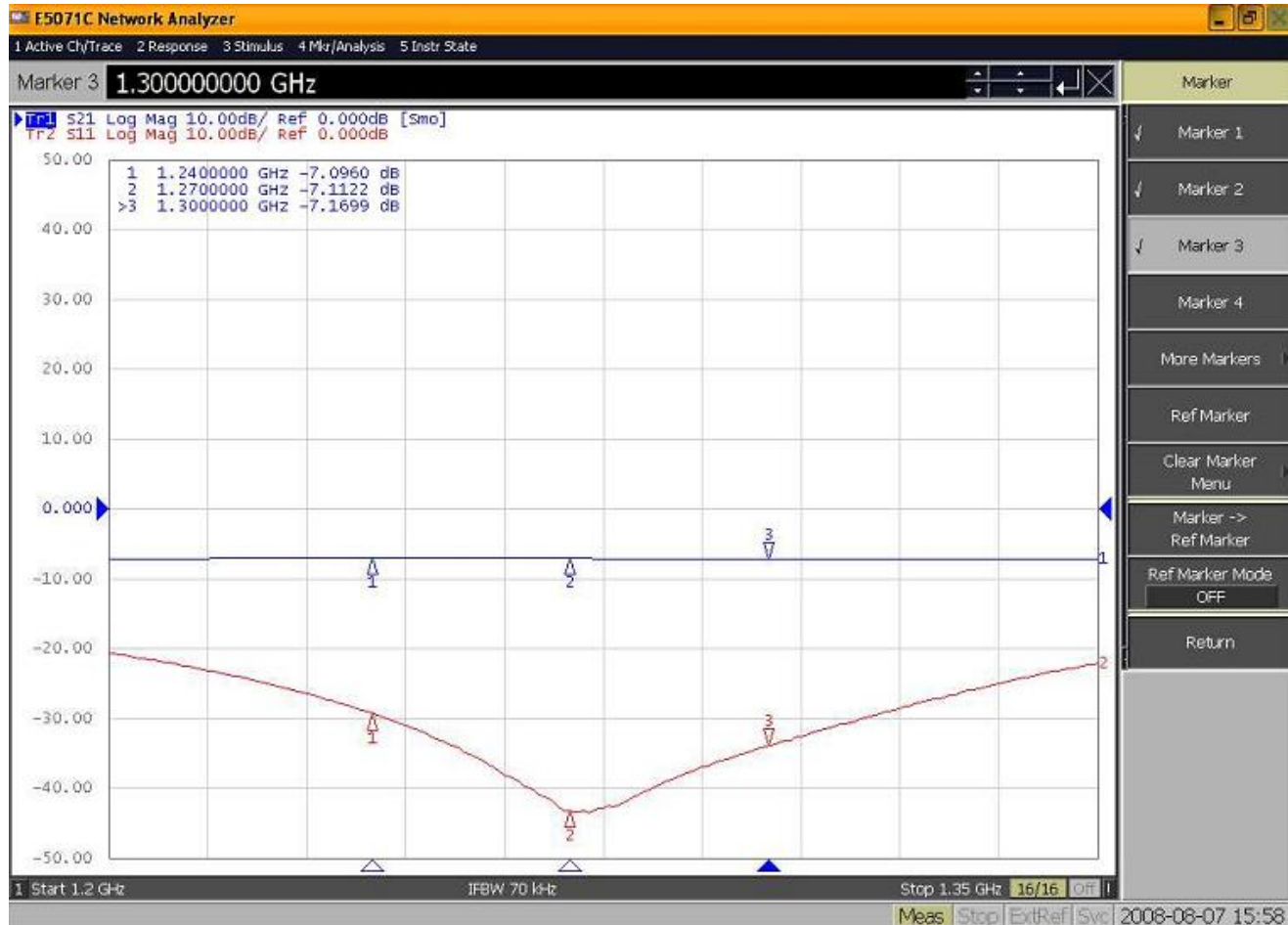

Four ports Wilkinson divider return and insertion loss

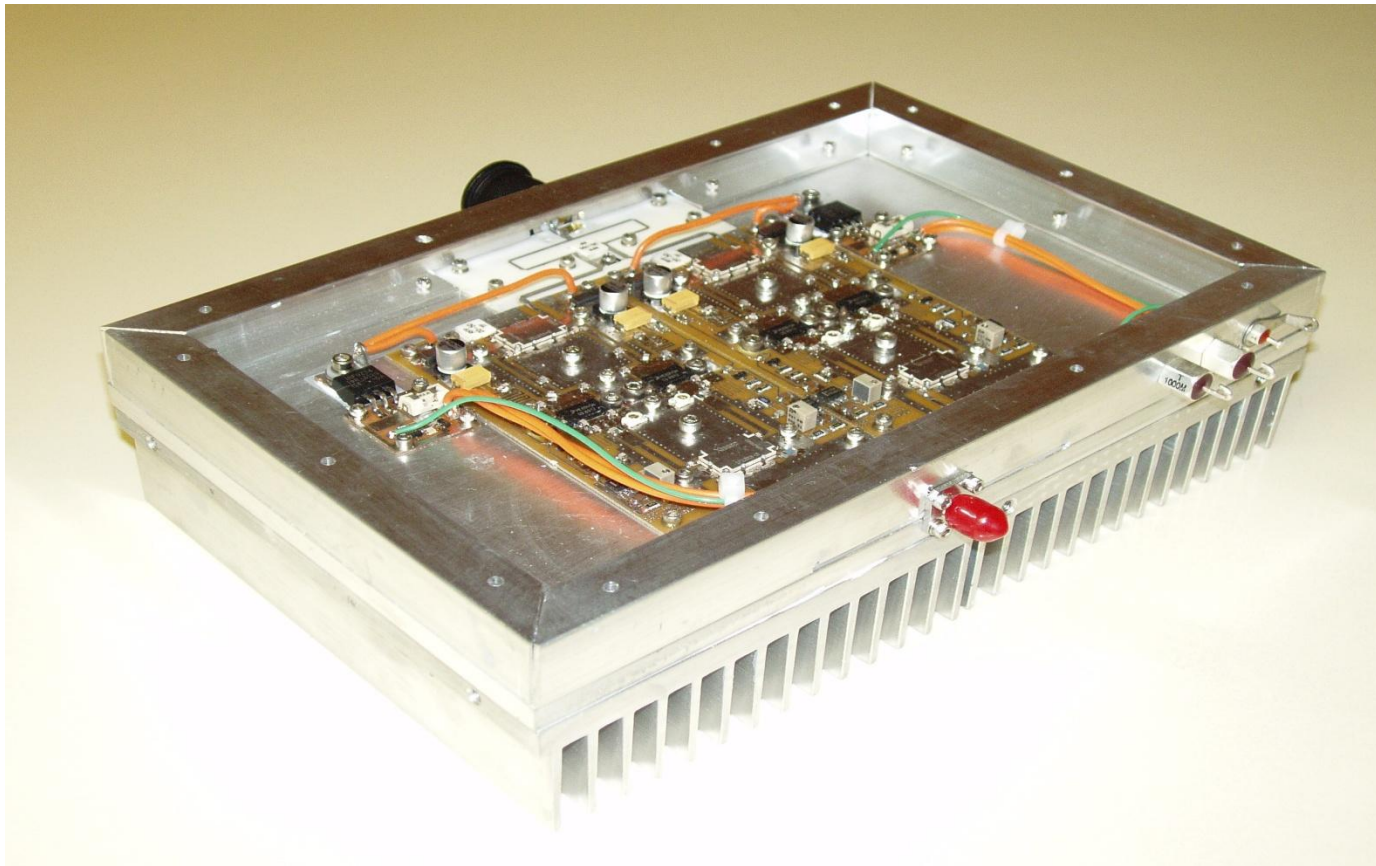

23 CM Amplifier 250W, drive 10W

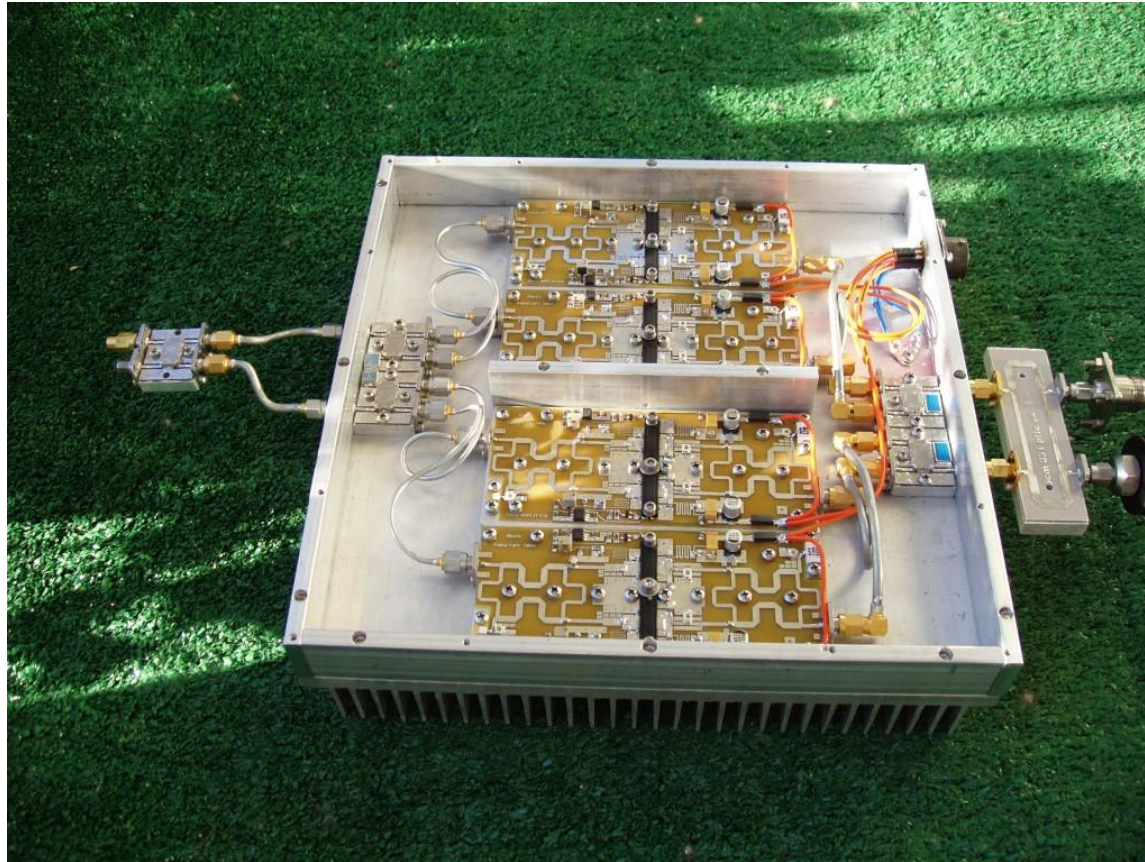

23 CM, 300W Amplifier prototype.
Used in EME operations with Jamesburg 30 Meters Dish

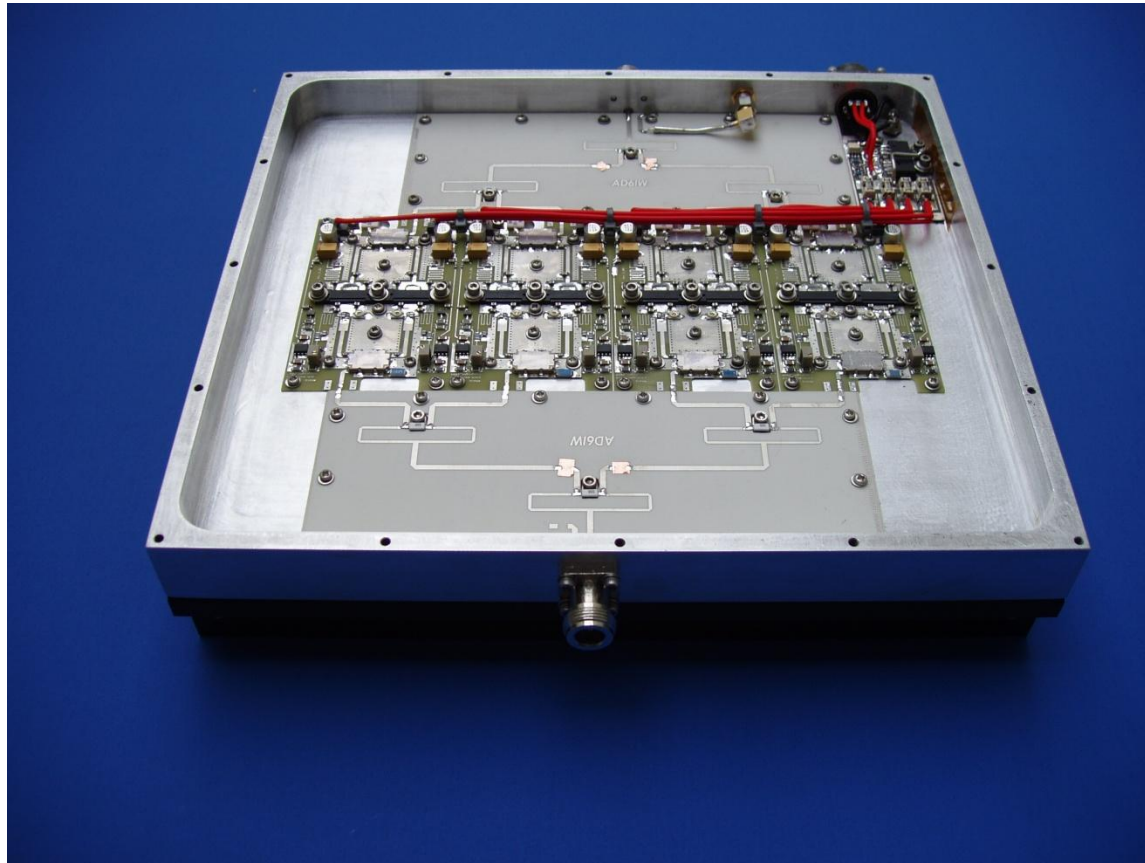

23 CM Amplifier 350 W

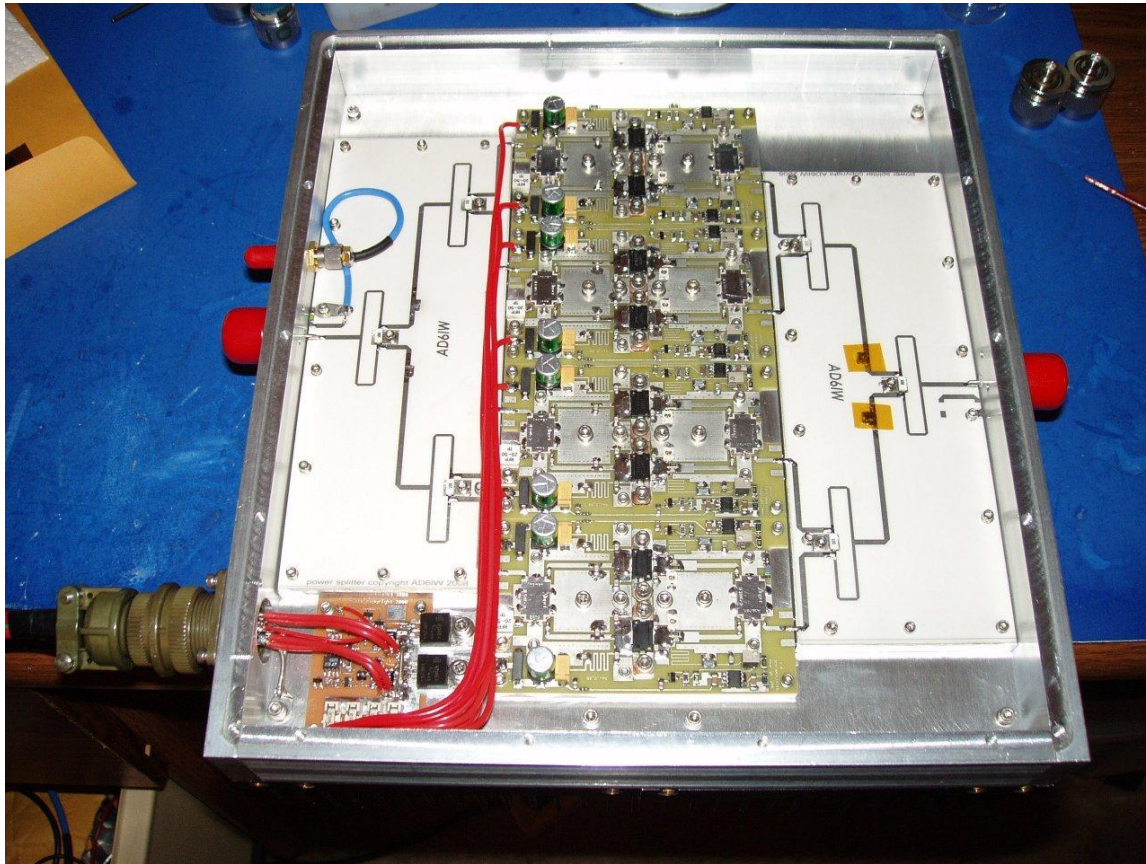

23 CM, 500W Amplifier, improved power and efficiency
with 6th generation of LDMOS

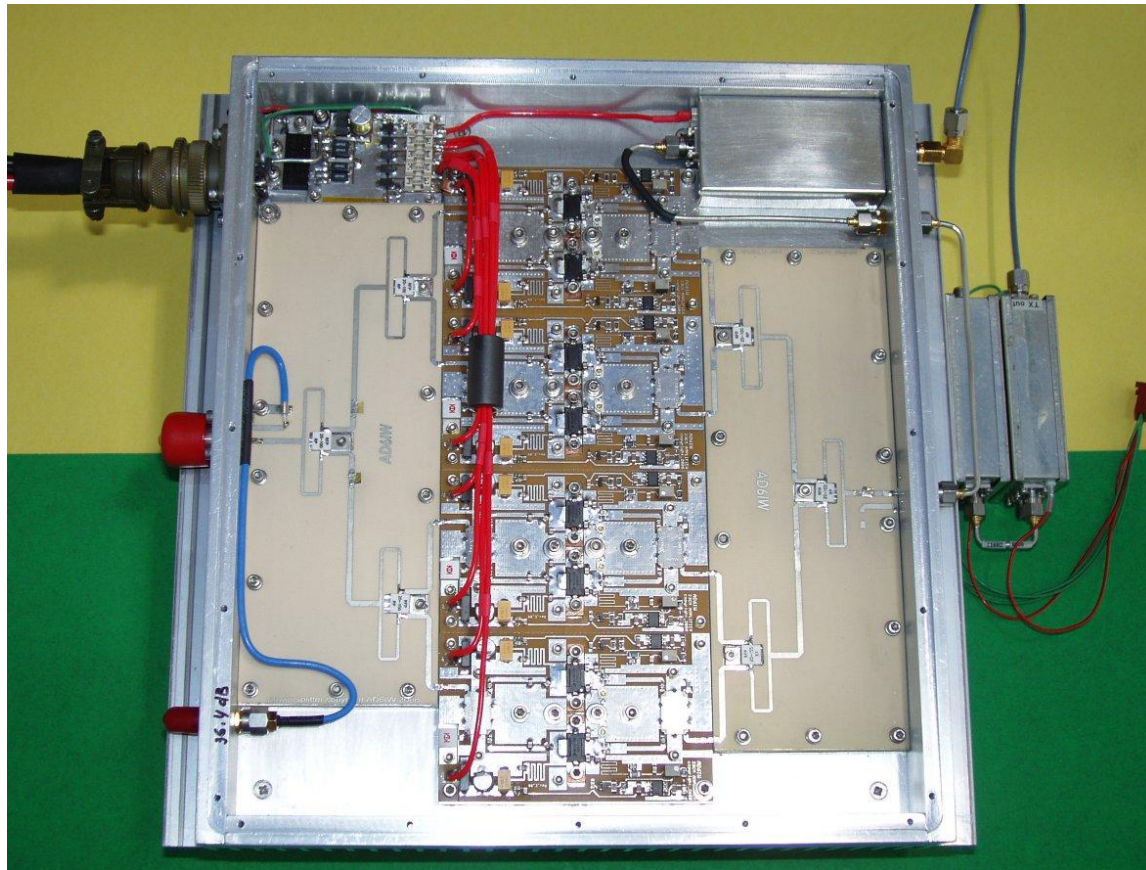

23CM High Gain Power Amplifier with transverter,
1W-in, 500W out

- Maresh Shah, Richard Rowan, Lu Li Quan Li, Eddie Mares, and Leonard Pelletier AN3789 Clamping of high power RF transistors and RFIC in Over-Molded plastic Packages
- Andreas Adahl, Herbert Zirath, An 1GHz Class E LDMOS Power Amplifier
- Andrei Grebennikov, Power Combiners, Impedance Transformers and Directional Couplers
- Antonio Equizabal, High Frequency Design, A 300W Power Amplifier for the 88 to 108 MHz FM broadcast Band
- Frederick H. Raab, Peter Asbeck, Steve Cripps, Peter B. Kenington, Zoya B. Popovic, Nick Pothecary, John F. Sevic and Nathan O. Sokal. High Frequency Design,
- RF and Microwave Power Amplifier and Transmitter Technologies part 1 to 4
- Alberto Asensio, José Luis Serrano, Javier Gismero and Alvaro Blanco Universidad Politécnica de Madrid, Department of Signals Systems and Radiocommunications, LDMOS Technology Solid-State Transmitter for MIDS Communications System
- UCSB diploma Thesis by Thomas Dellsperger, Device Evaluation for Current-Mode Class-D RF Power Amplifiers
- Wlodzimierz Janke, Jaroslaw Krasniewski, ISSN 0860-8229 M&M
- Investigation of Transient Thermal Characteristics of Microwave Transistors
- J.H.Harris, R.Enck, N. Leonardi, E. Rubel, CMC Interconnect Technologies
- Material and Interfacial Impact on Package Thermal Performance
- Seri Lee, Advanced Thermal Engineering, How to select a Heat Sink
- Bumjin Kim, D. Derikson, and C. Sun, California Polytechnic State University
- A High Power, High Efficiency Amplifier using GaN HEMT
- AN1955 Thermal Measurement Methodology of RF Power Amplifiers
- AN1233 LDMOS packages, Application note
- AN10885 Doherty RF performance analysis using the BLF7G22LS-130
- Darin Wagner, AN1941 Modeling Thermal Effect in LDMOS Transistors
- Nitronex Corporation, AN-011 Substrates for GaN RF Devices
- Nitronex Corporation, AN-012 Thermal Considerations for GaN Technology
- BLF645 NXP Data sheet
- Fujitsu Application Note 001
- Freescale, Semiconductor, AN3789 Clamping of High Power RF Transistors and RFIC in Over – Molded Plastic Package
- Andrei Grebennikov, Nathan O. Sokal, Switchmode RF Power Amplifiers 2007
- David M. Pozar, Microwave Engineering 1998

References